

INTRODUCTION

This device extends e2v's family of scientific CCD sensors. The CCD230 has been designed to provide a large image area for demanding scientific imaging applications. Back-illuminated spectral response combined with low readout noise give exceptional sensitivity. The device has been designed for applications such as low-noise spectroscopy and broadband imaging.

DESCRIPTION

The sensor has an image area having 4096 x 4096 pixels, split readout registers at both top and bottom with charge detection amplifiers at both ends. The pixel size is 15 μm square. The image area has four separately connected sections to allow full-frame, frame transfer, split full frame or split frame-transfer modes. Depending on the mode, the readout can be through 1, 2 or 4 of the output circuits. A gate-controlled drain is also provided to allow fast dumping of unwanted data.

The output amplifier is a two-stage type designed to give minimum noise at pixel rates as high as 5 MHz. The low output impedance of 400 Ω simplifies the interface with external electronics. Dummy outputs are also available to facilitate common mode rejection.

To achieve maximum full-well capacity, a four-phase image clocking sequence should be used. The detailed clock sequences are given in this data sheet.

The readout register is designed to accommodate at least four image pixels of charge, but the maximum signal then exceeds the capacity of the output circuit and a lower responsivity mode must be used.

This preliminary data sheet relates to the back-illuminated version of the device. Other variants are available.

Specifications are guaranteed and tested at $-25\text{ }^{\circ}\text{C}$.

OTHER VARIANTS

Alternate AR coatings and non-inverted-mode options (NIMO) can be provided. Devices with other formats (e.g. 8192 x 3172 pixels) or 3-side butting can also be provided.

A version (CCD231) is also available with very low noise amplifier but lower charge handling capacity and a slightly lower maximum operating frequency.

An alternate metal/flexi package is also available

Consult e2v technologies for further information.

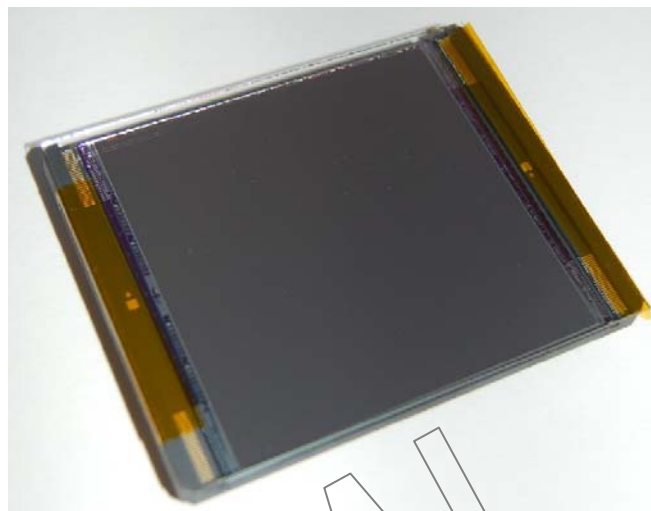

SUMMARY SPECIFICATION

Number of pixels	4096(H) x 4112(V)
Pixel size	15 μm square
Image area	61.4 mm x 61.4 mm
Outputs	4
Package size	TBD
Package format	aluminium oxide PGA
Focal plane height, above base	3.6 mm
Connectors	Pin Grid Array (PGA)
Flatness	<20 μm (peak to valley)
Amplifier sensitivity	2.5 $\mu\text{V}/\text{e}^-$
Readout noise	8 e^- at 1 MHz 4 e^- at 50 kHz
Maximum data rate	5 MHz
Charge storage	150,000 e^-
Dark signal	0.2 $\text{e}^-/\text{pixel}/\text{second}$ (at $-25\text{ }^{\circ}\text{C}$)

Quoted performance parameters given here are "typical" values. Specification limits are shown later in this data sheet.

Part References

CCD230-84-g-xxx
g = cosmetic grade
145 = mid-band coated IMO BI CCD230-84
E04 = broadband coated IMO BI CCD230-84
xxx = uncoated IMO BI CCD230-84

Whilst e2v technologies has taken care to ensure the accuracy of the information contained herein it accepts no responsibility for the consequences of any use thereof and also reserves the right to change the specification of goods without notice. e2v technologies accepts no liability beyond the set out in its standard conditions of sale in respect of infringement of third party patents arising from the use of tubes or other devices in accordance with information contained herein.

e2v technologies limited, Waterhouse Lane, Chelmsford, Essex CM1 2QU United Kingdom Telephone: +44 (0)1245 493493 Facsimile: +44 (0)1245 492492

e-mail: enquiries@e2v.com Internet: www.e2v.com Holding Company: e2v technologies plc

e2v technologies inc. 520 White Plains Road, Suite 450, Tarrytown, NY10591 USA Telephone: (914) 592-6050 Facsimile: (914) 592-5148 e-mail: enquiries@e2vtechnologies.us

PERFORMANCE (At 248 K unless stated)

Electro-Optical Specification

	Min	Typical	Max	Units	Note
Peak charge storage (image)	120,000	150,000	-	e ⁻ /pixel	2
Peak charge storage (register)	-	850,000	-	e ⁻ /pixel	
Output node capacity: OG low (mode 1)	-	450,000	-	e ⁻	3
OG high (mode 2)	-	900,000	-	e ⁻	
Output amplifier responsivity: mode 1	1.7	2.5	-	μV/e ⁻	3
mode 2	-	0.8	-	μV/e ⁻	
Readout noise	-	8	14	e ⁻ rms	4
Readout frequency	-	1000	5000	kHz	5
Dark signal (at 248 K)	-	0.2	2.0	e ⁻ /pixel/s	6
Charge transfer efficiency: parallel	99.9990	99.9995	100	%	7
serial	99.9990	99.9995	100	%	
Spectral range	300	-	1060	nm	

NOTES

1. Device performance will be within the limits specified by “max” and “min” when operated at the recommended voltages supplied with the test data and when measured at a register clock frequency of approximately 0.5 – 1.0 MHz. The noise as specified is separately measured in accordance with note 4.
2. Signal level at which resolution begins to degrade.
3. Under normal operation (mode 1), SW is operated as a summing well or clocked as RØ3. OG is biased at typically 2 V. Alternatively, SW may be operated as a second output gate (and not therefore available for summing), biased at typically 2 V with OG raised to a high voltage (mode 2) to give more charge handling capacity (e.g. for higher level pixel binning). With OG high, the output noise will also increase by a factor of two.
4. Measured with correlated double sampling at 750 kHz pixel rate.
5. Depending on the external load capacitance to be driven. The register will transfer charge at higher frequencies, but performance cannot be guaranteed.
6. Dark signal is typically measured with the substrate voltage at +9V and the device temperature 248 K. It is a strong function of temperature and the typical average (background) dark signal at any temperature T (kelvin) between 248 K and 300 K is given by:

$$Q_d/Q_{do} = 1.4 \times 10^6 T^3 e^{-9080/T}$$

where Q_{do} is the dark current at 293 K.

Transfer through the image sections can give rise to an additional temperature-independent component of “clock-induced charge” with of a magnitude in the region of 10^{-4} electrons per pixel transfer.

7. Measured with a ⁵⁵Fe X-ray source. The CTE value is quoted for the complete clock cycle (i.e. all phases).

COSMETIC SPECIFICATIONS

Maximum allowed defect levels are indicated below.

Grade	0	1	2
Column defects: black or white maximum adjacent	5 0	10 2	20 4
White spots	400	800	1200
Total (black & white) spots	800	1500	2000
Traps > 200e-	10	20	30

Grade 5 devices are fully functional but with an image quality below that of grade 2, and may not meet all other specifications. Not all parameters may be tested.

DEFINITIONS

White spots	A defect is counted as a white spot if the dark generation rate is $\geq 500 \text{ e}^-/\text{pixel}/\text{s}$ at 248 K. The typical temperature dependence is given by $Q_d/Q_{do} = 122T^3e^{-6400/T}$
Black spots	A black spot defect is a pixel with a response less than 80% of the local mean signal.
Column defects	A column is counted as a defect if it contains at least 50 white or dark single pixel defects.
Traps	A trap causes charge to be temporarily held in a pixel and these are counted as defects if the quantity of trapped charge is greater than 200 e^-
Defect exclusion zone	Defect measurements are excluded from the outer two rows and columns of the sensor.

TYPICAL OUTPUT AMPLIFIER NOISE

The variation of typical read noise with operating frequency is shown below. (Measured using correlated double sampling with a pre-sampling bandwidth equal to twice the pixel rate in mode 1 at approximately 248 K).

Estimated Read Noise (BI)

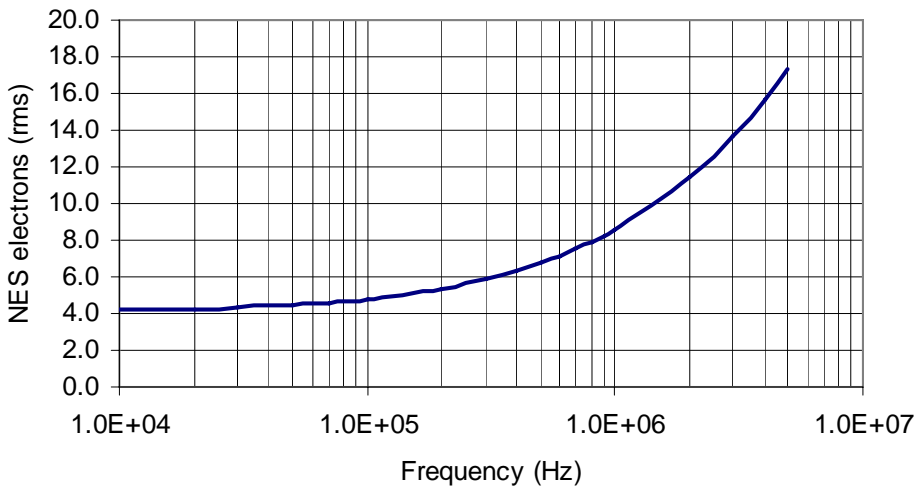

SPECTRAL RESPONSE AT -25°C

The table below gives guaranteed minimum values of the spectral response for several variants.

	Mid Band Coated	Broadband Coated	No AR Coating	Maximum Pixel Response Non-Uniformity PRNU (1 σ) (%)
Wavelength (nm)	Minimum QE (%)	Minimum QE (%)	Minimum QE (%)	
350	15	25	10	5
400	40	55	25	3
500	85	75	55	3
650	85	75	50	3
900	30	30	30	5

See also the figure below for details of the standard AR coatings available. These must be identified by means of the three-digit identifier in the part reference number. Devices with an alternate spectral response may be available; consult e2v for details.

Typical QE at -25C

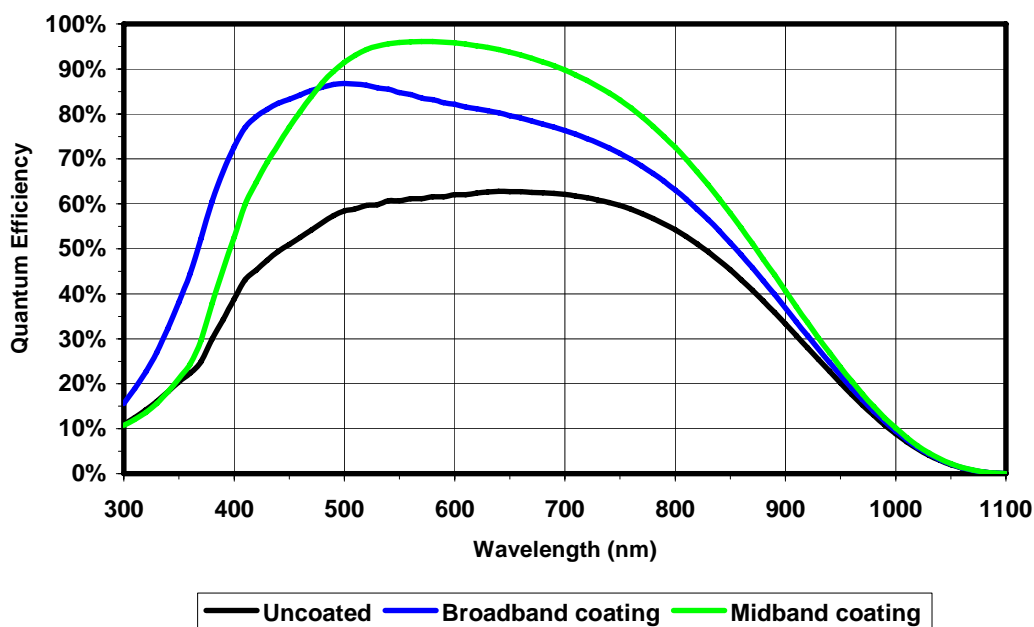

DEFINITIONS

Back-Thinning

A back-thinned CCD is fabricated on the front surface of the silicon and is subsequently processed for illumination from the reverse side. This avoids loss of transmission in the electrode layer (particularly significant at shorter wavelengths or with low energy X-rays). This process requires the silicon to be reduced to a thin layer by a combination of chemical and mechanical means. The surface is "passivated" and an anti-reflection coating may be added.

AR Coating

Anti-reflection coatings are normally applied to the back illuminated CCD to further improve the quantum efficiency. Standard coatings optimise the response in the visible, ultra-violet or infrared regions. For X-ray detection an uncoated device may be preferable.

Inverted Mode (IMO)

An inverted mode CCD has an additional implant that allows charge integration to be carried out with all clock phases low. With a high voltage applied to the substrate (typically +9 V) this causes the whole of the device to be flooded with holes (inverted or pinned), which suppresses the surface component of dark signal. This leaves only the much lower bulk component, reducing the overall dark signal by a factor of approximately 100.

Inverted mode operation is also referred to as multi-phase pinning (MPP).

Readout Noise

Readout noise is the random noise from the CCD output stage in the absence of signal. This noise introduces a random fluctuation in the output voltage that is superimposed on the detected signal.

The method of measurement involves reverse-clocking the register and determining the standard deviation of the output fluctuations, and then converting the result to an equivalent number of electrons using the known amplifier responsivity.

Dummy Output

Each output has an associated "dummy" circuit on-chip, which is of identical design to the "real" circuit but receives no signal charge. The dummy output should have the same levels of clock feed-through, and can thus be used to suppress the similar component in the "real" signal output by means of a differential pre-amplifier. The penalty is that the noise is increased by a factor of $\sqrt{2}$. If not required the dummy outputs may be powered down.

Dark Signal

This is the output signal of the device with zero illumination. This typically consists of thermally generated electrons within the semiconductor material, which are accumulated during signal integration. Dark signal is a strong function of temperature as described in note 6.

Correlated Double Sampling

A technique for reducing the noise associated with the charge detection process by subtracting a first output sample taken just after reset from a second sample taken with charge present.

Charge Transfer Efficiency

The fraction of charge stored in a CCD element that is transferred to the adjacent element by a single clock cycle. The charge not transferred remains in the original element, possibly in trapping states and may possibly be released into later elements. The value of CTE is not constant but varies with signal size, temperature and clock frequency.

ARCHITECTURE

Chip Schematic

TOP

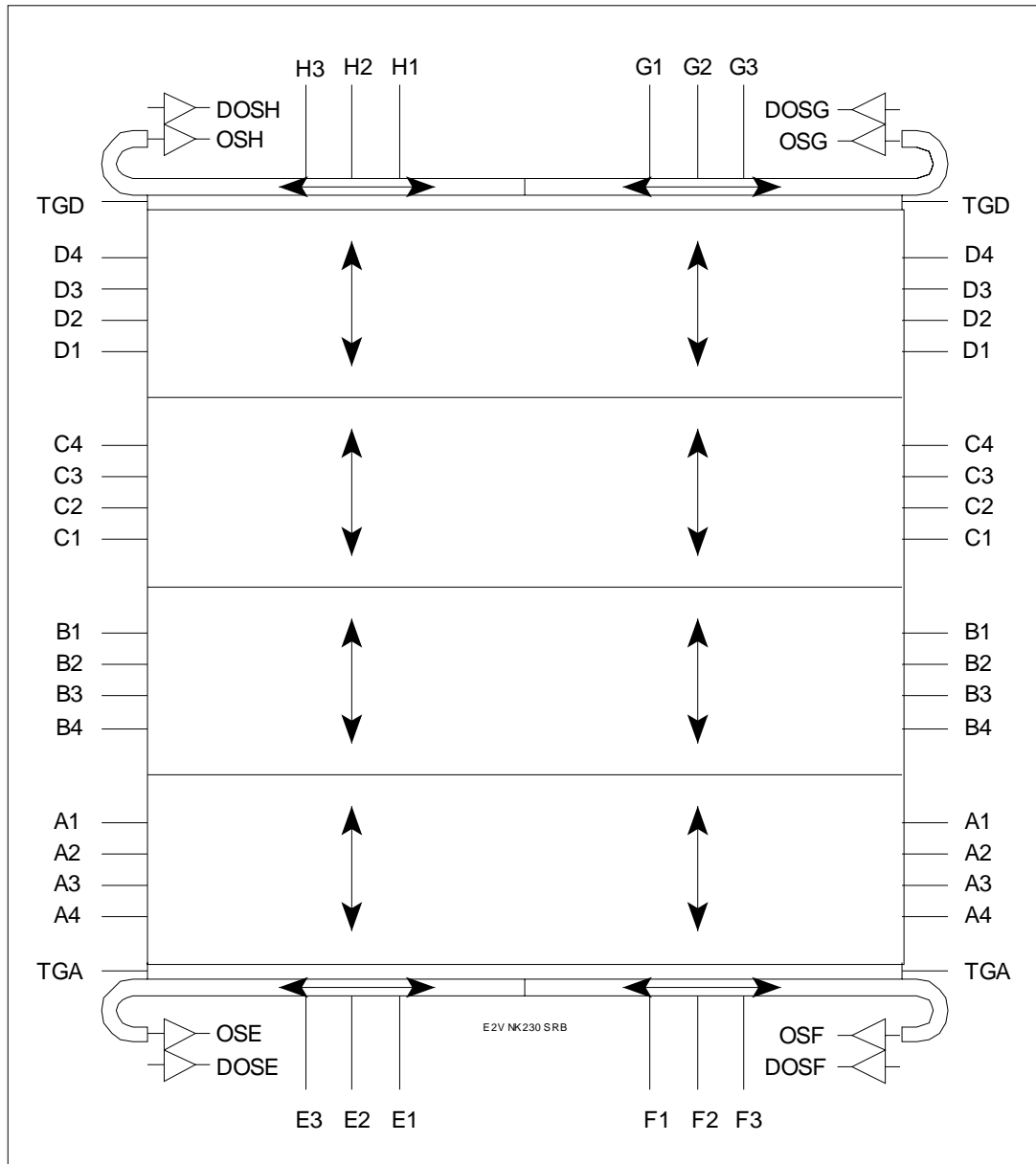

BOTTOM

ARRANGEMENT OF ELECTRODES

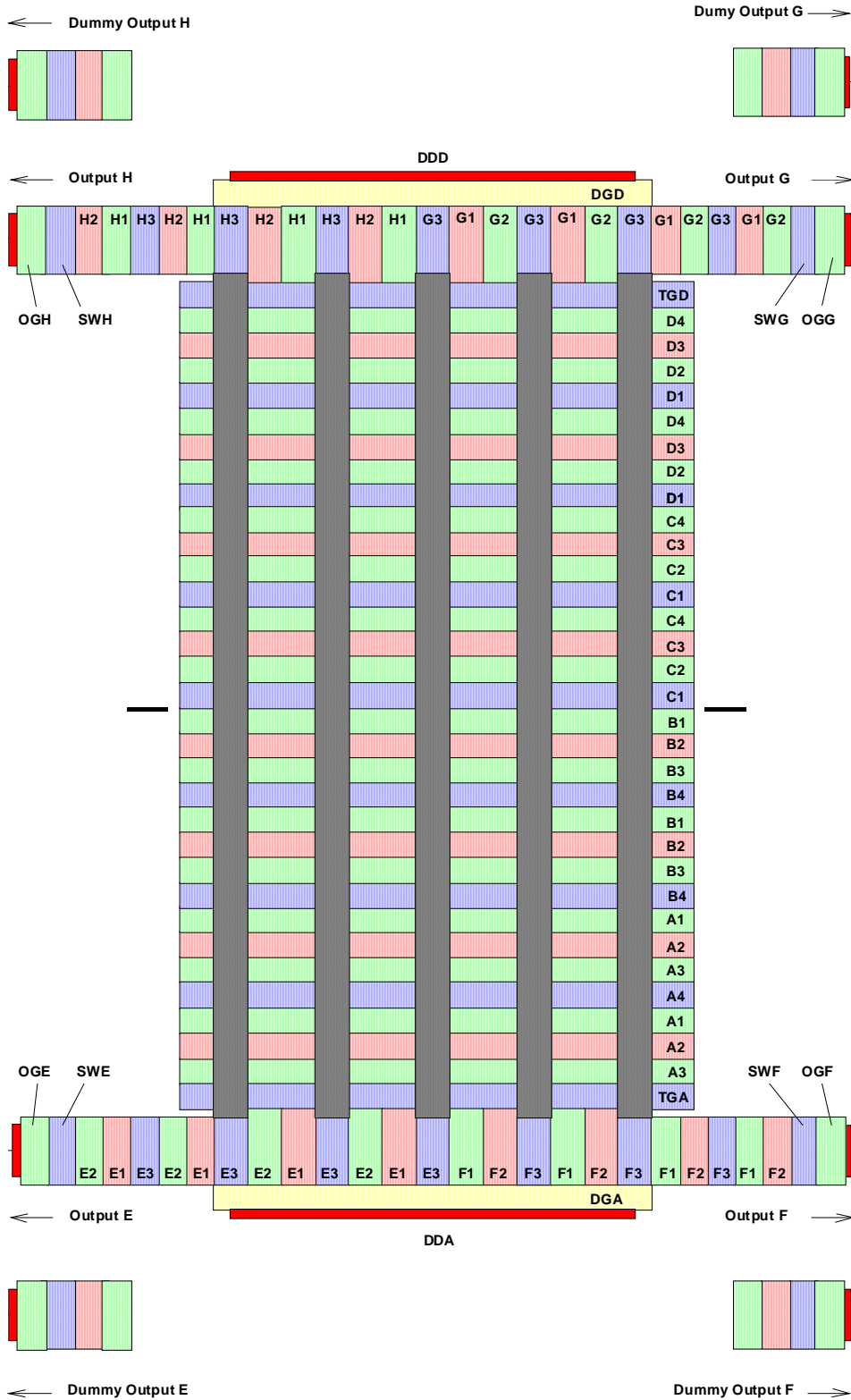

The IMO implant is under image phases A4, B4, C1, D1 and the transfer gates as shown below.

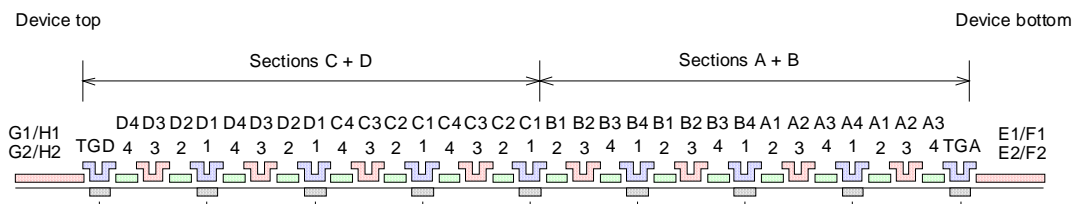

OUTPUT CIRCUIT (Active “real” and “dummy” outputs)

X designates a specific output, namely E, F, G or H

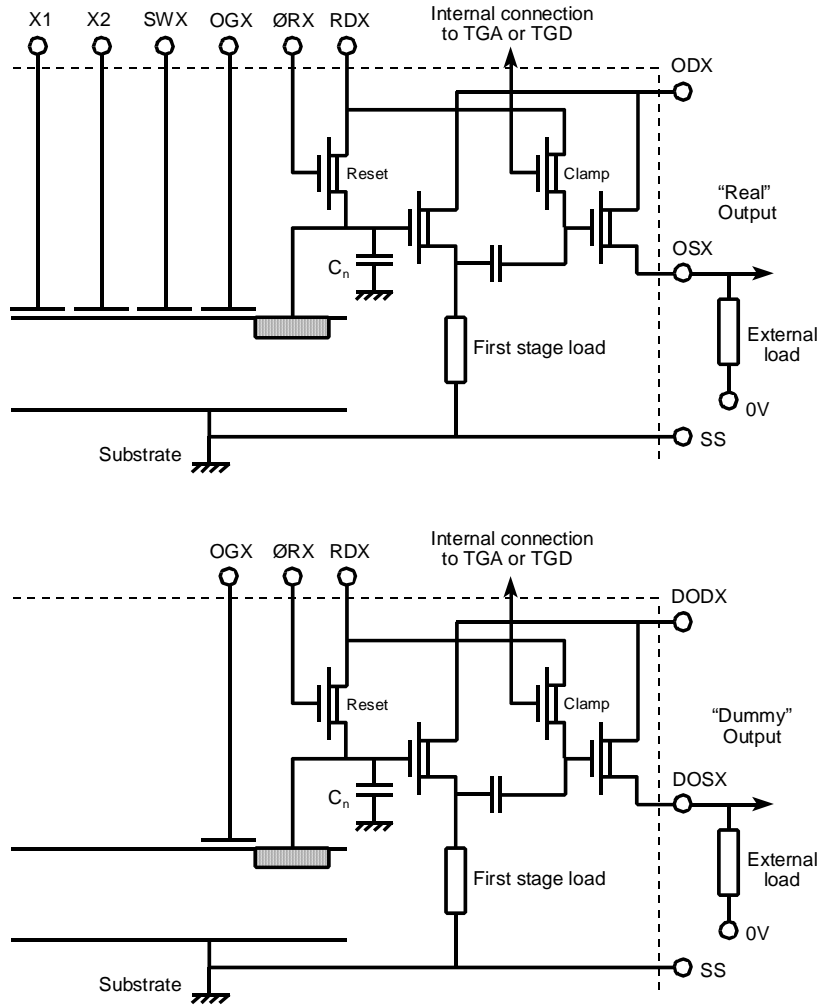

The first stage load of each output (real or dummy) draws a quiescent current of approximately 0.3 mA.

The output circuit consists of two capacitor-coupled source-follower stages. This particular design has a reduced responsivity to allow binning of large charge packets. The load for the first stage is on-chip and that for the second stage is external, as next described. The DC restoration circuitry requires a pulse at the start of line readout, and this is automatically obtained by an internal connection to the adjacent transfer gate, TG. Transferring a line of charges to the register thus automatically activates the circuitry. N.B. TG pulses still need to be applied at similar intervals if only the register and/or output circuit are being operated, e.g. for test or characterisation purposes.

If an output is to be powered down, it is recommended that either OD or DOD be set to SS voltage, taking care that the maximum ratings are never exceeded or that OD and DOD be disconnected. If external loads return to a voltage below SS they should also be disconnected.

ELECTRICAL INTERFACE

CONNECTIONS, TYPICAL VOLTAGES AND ABSOLUTE MAXIMUM RATINGS

The tables below give the pin-outs and clock amplitudes. Note that the hyphenated suffix symbols (e.g. ØR-H) indicate to which amplifier the CCD pin relates.

PIN	REF	DESCRIPTION	CLOCK AMPLITUDE OR DC LEVEL (V) (see note 10)			MAX RATINGS with respect to V _{SS} (V)
			Min	Typical	Max	
1	DOS-E	Dummy Output Source (E)	(see note 8)			-0.3 to +25
2	DOD-E	Dummy Output Drain (E)	27	29	31	29
3	OS-E	Output Source (E)	(see note 8)			-0.3 to +25
4	OD-E	Output Drain (E)	27	29	31	-0.3 to +35
5	RD-E	Reset Drain (E)	16	17	19	-0.3 to +25
6	SS	Substrate	8	9	10.5	N/A
7	OG-E	Output Gate (E) (see note 9)	1	2	5	±20
8	SWØ-E	Summing Well (E) (see note 9)	9	10	12	±20
9	E3	Register Clock Phase 3 (E)	9	10	12	±20
10	ØR-E	Reset Gate (E)	9	10	12	±20
11	E2	Register Clock Phase 2 (E)	9	10	12	±20
12	E1	Register Clock Phase 1 (E)	9	10	12	±20
13	A1	Image Area Clock Phase 1 (A)	9	10	12	±20
14	SS	Substrate	8	9	10.5	N/A
15	A2	Image Area Clock Phase 2 (A)	9	10	12	±20
16	A3	Image Area Clock Phase 3 (A)	9	10	12	±20
17	SS	Substrate	8	9	10.5	N/A
18	A4	Image Area Clock Phase 4 (A)	9	10	12	±20
19	TS-1	Temperature Sensor 1 – Pin 1	(see note 12)			N/A
20	DG-A	Dump Gate (A) (see note 11)	-2	0	0.5	±20
21	TS-2	Temperature Sensor 1 – Pin 2	(see note 12)			N/A
22	DD-A	Dump Drain (A)	27	29	31	-0.3 to +35
23	TG-A	Transfer Gate (A)	9	10	12	±20
24	B4	Image Area Clock Phase 4 (B)	9	10	12	±20
25	B2	Image Area Clock Phase 2 (B)	9	10	12	±20
26	B3	Image Area Clock Phase 3 (B)	9	10	12	±20
27	B1	Image Area Clock Phase 1 (B)	9	10	12	±20
28	SS	Substrate	8	9	10.5	N/A
29	F1	Register Clock Phase 1 (F)	9	10	12	±20
30	F2	Register Clock Phase 2 (F)	9	10	12	±20
31	F3	Register Clock Phase 3 (F)	9	10	12	±20
32	ØR-F	Reset Gate (F)	9	10	11	±20
33	OG-F	Output Gate (F) (see note 9)	1	2	5	±20
34	SWØ-F	Summing Well (F) (see note 9)	9	10	12	±20
35	RD-F	Reset Drain (F)	16	17	19	-0.3 to +25
36	SS	Substrate	8	9	10.5	N/A
37	OS-F	Output Source (F)	(see note 8)			-0.3 to +25
38	OD-F	Output Drain (F)	27	29	31	-0.3 to +35
39	DOS-F	Dummy Output Source (F)	(see note 8)			-0.3 to +25
40	DOD-F	Dummy Output Drain (F)	27	29	31	-0.3 to +35

PIN	REF	DESCRIPTION	CLOCK AMPLITUDE OR DC LEVEL (V) (see note 10)			MAX RATINGS with respect to V _{ss} (V)
			Min	Typical	Max	
41	DOS-G	Dummy Output Source (G)	(see note 8)			-0.3 to +25
42	DOD-G	Dummy Output Drain (G)	27	29	31	29
43	OS-G	Output Source (G)	(see note 8)			-0.3 to +25
44	OD-G	Output Drain (G)	27	29	31	-0.3 to +35
45	RD-G	Reset Drain (G)	16	17	19	-0.3 to +25
46	SS	Substrate	8	9	10.5	N/A
47	OG-G	Output Gate (G) (see note 9)	1	2	5	±20
48	SWØ-G	Summing Well (G) (see note 9)	9	10	12	±20
49	G3	Register Clock Phase 3 (G)	9	10	12	±20
50	ØR-G	Reset Gate (G)	9	10	12	±20
51	G2	Register Clock Phase 2 (G)	9	10	12	±20
52	G1	Register Clock Phase 1 (G)	9	10	12	±20
53	D4	Image Area Clock Phase 4 (D)	9	10	12	±20
54	SS	Substrate	8	9	10.5	N/A
55	D3	Image Area Clock Phase 3 (D)	9	10	12	±20
56	D2	Image Area Clock Phase 2 (D)	9	10	12	±20
57	SS	Substrate	8	9	10.5	N/A
58	D1	Image Area Clock Phase 1 (D)	9	10	11	±20
59	TS-3	Temperature Sensor 2 – Pin 1	(see note 12)			N/A
60	DG-D	Dump Gate (D) (see note 11)	-2	0	0.5	±20
61	TS-4	Temperature Sensor 2 – Pin 2	(see note 12)			N/A
62	DD-D	Dump Drain (D)	27	29	31	-0.3 to +35
63	TG-D	Transfer Gate (D)	9	10	12	±20
64	C1	Image Area Clock Phase 1 (C)	9	10	12	±20
65	C3	Image Area Clock Phase 3 (C)	9	10	12	±20
66	C2	Image Area Clock Phase 2 (C)	9	10	12	±20
67	C4	Image Area Clock Phase 4 (C)	9	10	12	±20
68	SS	Substrate	8	9	10.5	N/A
69	H1	Register Clock Phase 1 (H)	9	10	12	±20
70	H2	Register Clock Phase 2 (H)	9	10	12	±20
71	H3	Register Clock Phase 3 (H)	9	10	12	±20
72	ØR-H	Reset Gate (H)	9	10	11	±20
73	OGH	Output Gate (H) (see note 9)	1	2	5	±20
74	SWØ-H	Summing Well (H) (see note 9)	9	10	12	±20
75	RD-H	Reset Drain (H)	16	17	19	-0.3 to +25
76	SS	Substrate	8	9	10.5	N/A
77	OS-H	Output Source (H)	(see note 8)			-0.3 to +25
78	OD-H	Output Drain (H)	27	29	31	-0.3 to +35
79	DOS-H	Dummy Output Source (H)	(see note 8)			-0.3 to +25
80	DOD-H	Dummy Output Drain (H)	27	29	31	-0.3 to +35

See Notes Overleaf

NOTES

8. Do not connect to voltage supply but use a ~5 mA current source or a ~5 kΩ external load. The quiescent voltage on OS is then about 6 - 8 V above the reset drain voltage and is typically 24 V. The current through these pins must not exceed 20 mA. Permanent damage may result if, in operation, OS or DOS experience short circuit conditions.

For highest speed operation the output load resistor can be reduced from 5 kΩ to approximately 2.2 kΩ, but note that this will increase power consumption. If the device is to be operated with a register clock period of below about 1 MHz then the load may be increased to 10 kΩ to reduce power consumption.

In order to ensure that the amplifier is well settled the output load capacitance should be minimised (typically <20 pF) for the highest readout rate.

9. Default operation (mode 1) shown with OG at +2 V typical. In this mode SW may be clocked as RØ3 if a summing well function is not required.

For alternative operation in a low responsivity mode with increased charge handling, OG should be set to +20 V and SW should be operated as OG. Charge is now read out as RØ2 goes low.

10. To ensure that any device can be operated the camera should be designed so that any value in the range "min" to "max" can be provided. All operating voltages are with respect to image clock low (nominally 0 V).

The clock pulse low levels should be in the range 0 ± 0.5 V for image, register, SW and DG clocks.

11. Non-charge dumping level shown. For charge dumping, DG should be pulsed to 12 ± 2 V (this may be provided from a common rail to the register clocks).

12. Two Fenwal NTC 196-LAD302-002 negative temperature coefficient thermistors are provided in the package for thermal control purposes.

13. This data sheet assumes that all signals are relative to the clock low level of 0V .The absolute level for all biases and clock rails may be changed to suit the needs of the designer provided the relative levels are maintained. For example, it is acceptable to set Vss to 0 V so long as the specified difference between Vss and all other bias and clock voltages is maintained and the current load on all output sources is as recommended in note 8.

14. DD and OD may be provided from a common rail provided that they are separately filtered sufficiently to ensure that there is no clock pick-up on OD.

15. Image and register clock high voltages may be provided from common rails.

PIN CONNECTIONS (View facing underside of package)

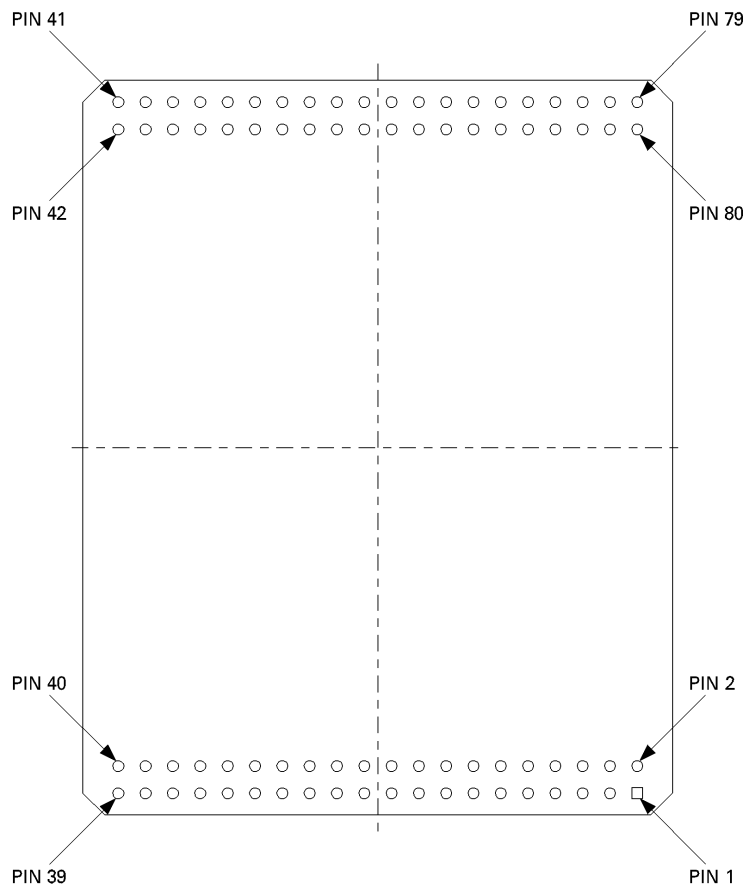

ELECTRICAL INTERFACE CHARACTERISTICS

Electrode capacitances (defined at mid-clock level)

	Typical	Units
I \emptyset /I \emptyset inter-phase [A, B, C and D]	10	nF
I \emptyset /SS [A1, A2, A3, B1, B2, B3, C2, C3, C4, D2, D3, D4]	20	nF
I \emptyset /SS [4-A, 4-B, 1-C, 1-D]	50	nF
Transfer gates [TGA, TGD]	130	pF
R \emptyset /(SS + DG + DD) [E1, F1, G1, H1]	190	pF
R \emptyset /(SS + DG + DD) [E2, F2, G2, H2]	175	pF
R \emptyset /(SS + DG + DD) [E3, F3, G3, H3]	155	pF

The total capacitance on each phase is the sum of the inter-phase capacitance to each of the adjacent phases and the capacitance of the phase to substrate. For example, the total capacitance on phase A1 is 2 times 10 nF plus 20 nF for a total of 40 nF.

The amplifier output impedance is typically 400 Ω .

POWER UP/POWER DOWN

When powering the device up or down it is critical that any specified maximum rating is not exceeded. Specifically the voltage for the amplifier and dump drains (pins 2, 4, 5, 22, 35, 38, 40, 42, 44, 45, 62, 75, 78 and 80) must never be taken negative with respect to the substrate. Hence, if the substrate is to be operated at a positive voltage (e.g. to minimise dark current) then the drive electronics should have a switch-on sequence which powers up all the drains to their positive voltages before the substrate voltage starts to increase from zero.

It is also important to ensure that excess currents (see note 8) do not flow in the OS or DOS pins. Such currents could arise from rapid charging of a signal coupling capacitor or from an incorrectly biased DC-coupled preamplifier.

Similarly, for powering down, the substrate must be taken to zero voltage before the drains.

POWER CONSUMPTION

The power dissipated within the CCD is a combination of the static dissipation of the amplifiers and the dynamic dissipation from the parallel and serial clocking (i.e. driving the capacitive loads).

The table below gives representative values for the components of the on-chip power dissipation for the case of continuous split-frame line-by-line read-out using both registers and all the output circuits with both real and dummy amplifiers activated. The frequency is that for clocking the serial register and an appropriate value of the amplifier load is utilised in each case.

Readout frequency	Line time	Amplifier load	Power dissipation			
			Amplifiers	Serial clocks	Parallel clocks	Total
100 kHz	21 ms	10 k Ω	165 mW	17 mW	3 mW	185 mW
1 MHz	2.2 ms	5 k Ω	275 mW	170 mW	30 mW	475 mW
3 MHz	800 μ s	2.2 k Ω	525 mW	510 mW	90 mW	1,125 mW

The dissipation reduces to only that of the amplifiers during the time that charge is being collected in the image sections with both the parallel and serial clocks static.

FRAME READOUT MODES

The device can be operated in a full-frame or frame transfer mode with readout from one, two or four amplifiers. These modes are determined by the clock pulse sequences applied to the image and register clocks. The diagrams below show some of the transfer options that are possible.

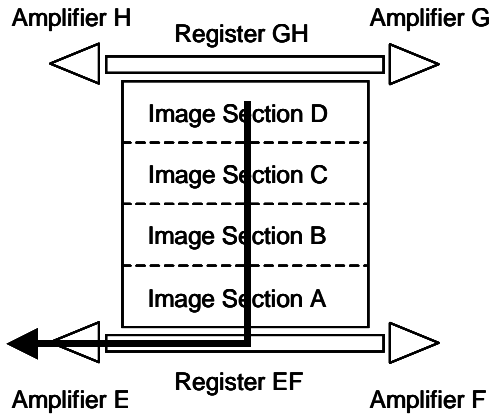

Full frame read-out through one amplifier

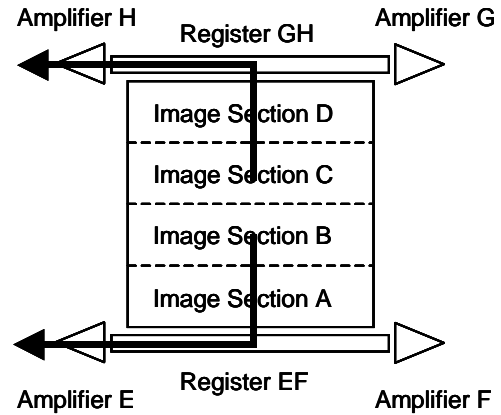

Split full frame read-out through two amplifiers

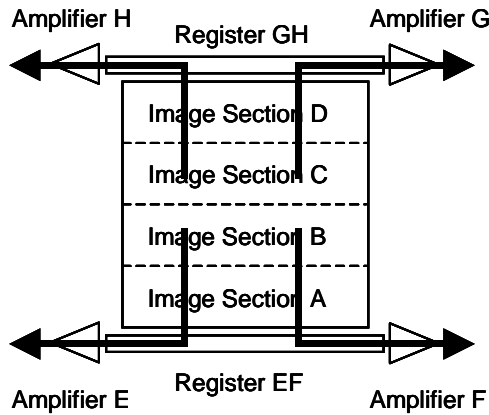

Split full frame read-out through four amplifiers

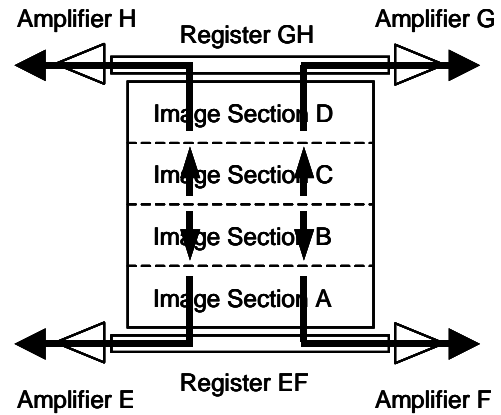

Split frame transfer through four amplifiers

If the applied drive pulses are designated IØ1, IØ2, IØ3 and IØ4, then connections should be made as tabulated below to effect the following directions of transfer.

	IØ1	IØ2	IØ3	IØ4	
A section transfer towards E-F register	A4	A1	A2	A3	TGA = IØ1
B section transfer towards E-F register	B4	B1	B2	B3	
C section transfer towards G-H register	C1	C2	C3	C4	
D section transfer towards G-H register	D1	D2	D3	D4	TGD = IØ1
A section transfer towards G-H register	A4	A3	A2	A1	TGA = "low"
B section transfer towards G-H register	B4	B3	B2	B1	
C section transfer towards E-F register	C1	C4	C3	C2	
D section transfer towards E-F register	D1	D4	D3	D2	TGD = "low"

The first four transfer sequences are for split full-frame readout. The second four are for reversing the transfer direction in either section for readout to only one of the registers.

Transfer from the image section to the register is into the phase 1 and 2 electrodes, i.e. E1, F1, G1, H1, E2, F2, G2 and H2. These electrodes must be held at clock "high" level during the process. If the register pulses are designated RØ1, RØ2 and RØ3, then connections should be made as tabulated below to effect the following directions of transfer.

Clock Generator Drive Pulse Name	RØ1	RØ2	RØ3
E section transfer towards E output	E2	E1	E3
F section transfer towards F output	F2	F1	F3
G section transfer towards G output	G2	G1	G3
H section transfer towards H output	H2	H1	H3
E section transfer towards F output	E1	E2	E3
F section transfer towards E output	F1	F2	F3
G section transfer towards H output	G1	G2	G3
H section transfer towards G output	H1	H2	H3

The first four sequences are for split register readout to all four outputs. The second four are for the reversal of direction in any half-section.

The last electrode before the output gate is separately connected to give the function of a summing well (SW). In normal readout (i.e. if not used for summing), SW is clocked as RØ3. For summing, the selected SW gate is held at clock "high" level for the required number of readout cycles, and then clocked as RØ3 to output charge.

Alternatively, SW may be operated as a second output gate to provide the option of operation in low gain/high signal mode (mode 2) with OG high. If this mode of operation is used, then the sequencing of the output clocks must be changed, as charge will be transferred into the output node as RØ2 goes low (see note 9).

FRAME READOUT TIMING DIAGRAM

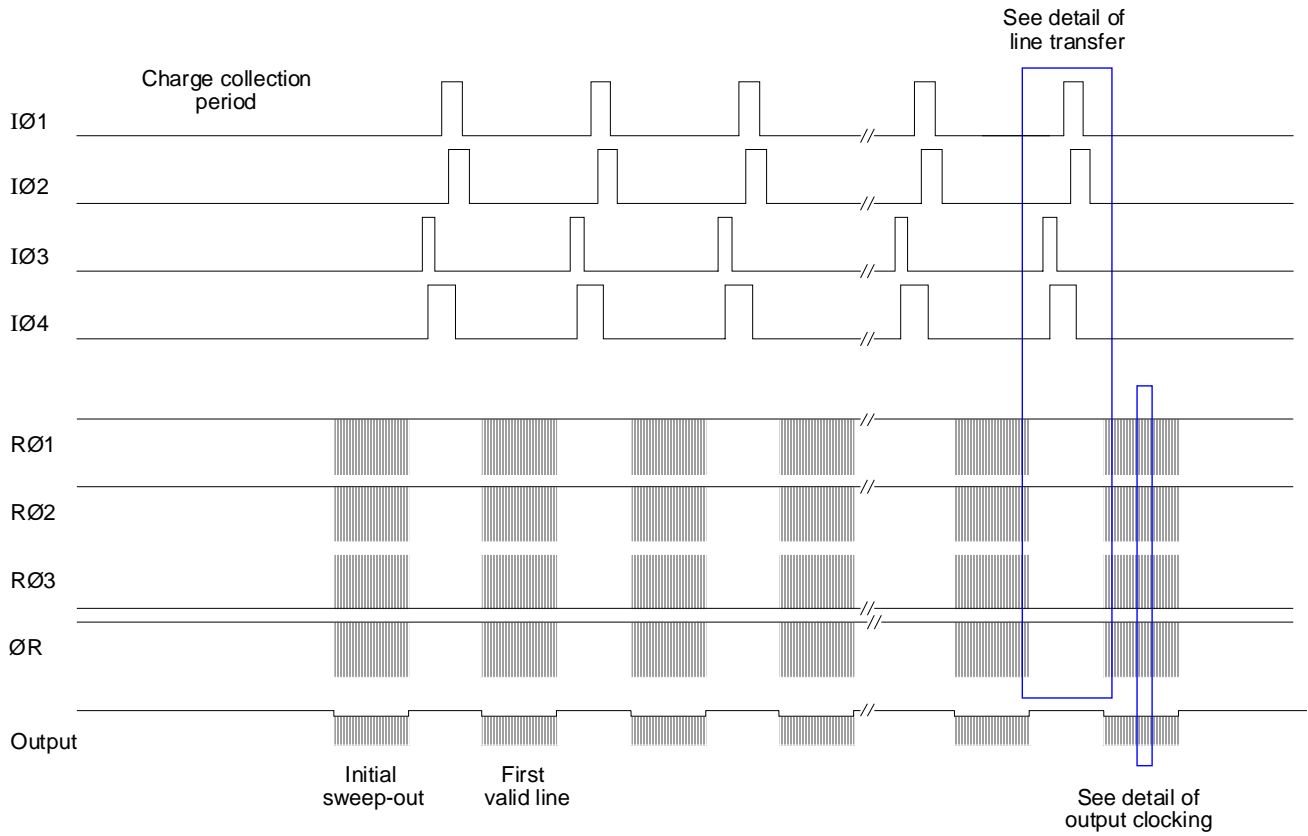

DETAIL OF LINE TRANSFER

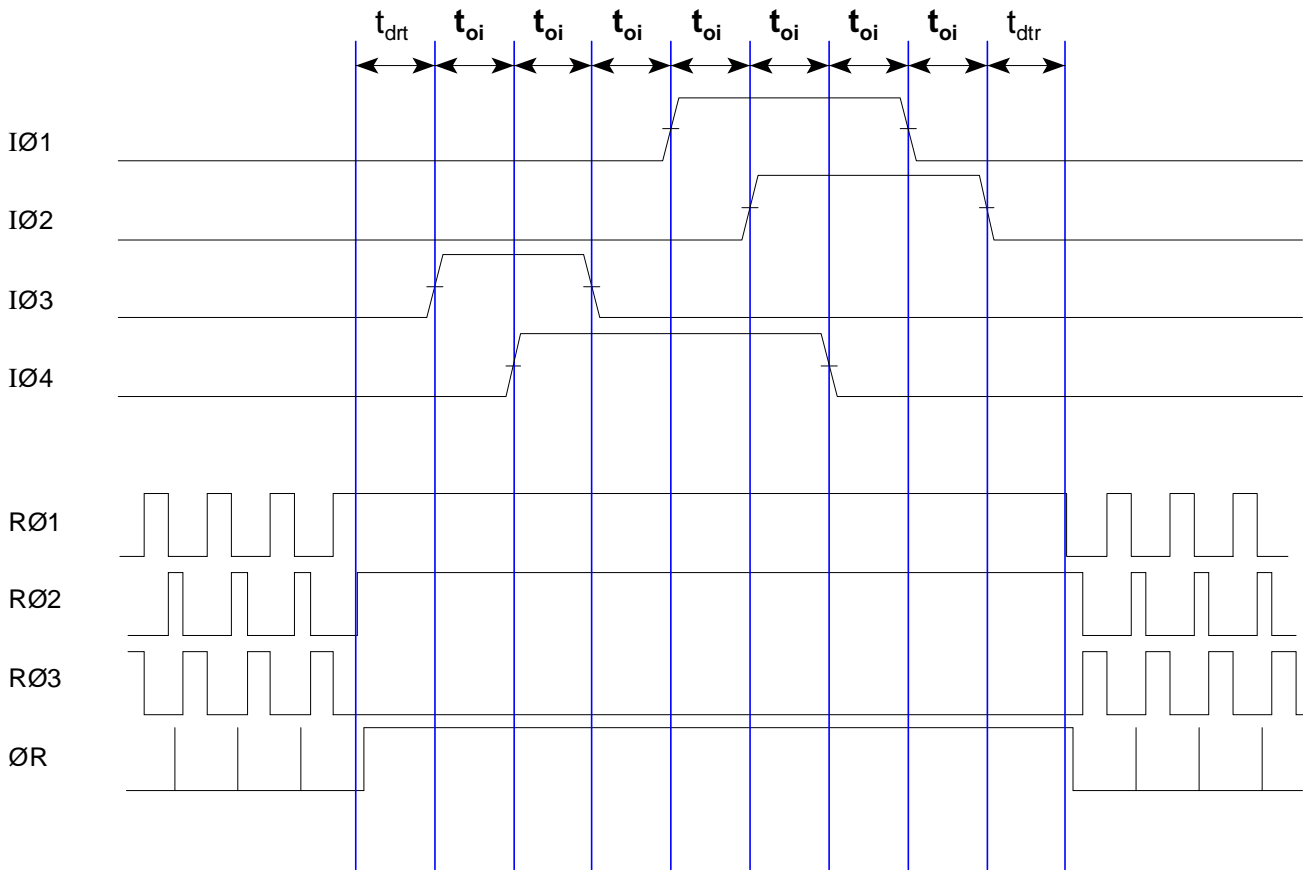

DETAIL OF OUTPUT CLOCKING (with SW clocked as RØ3)

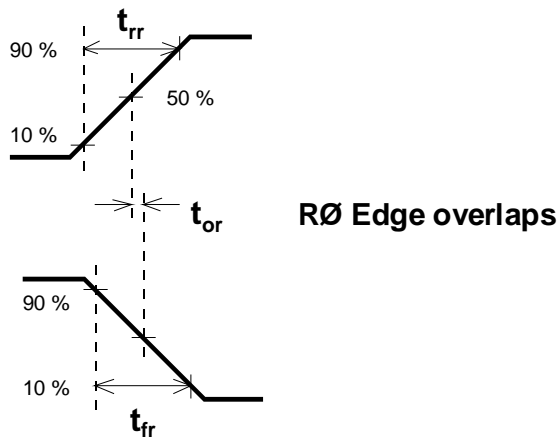
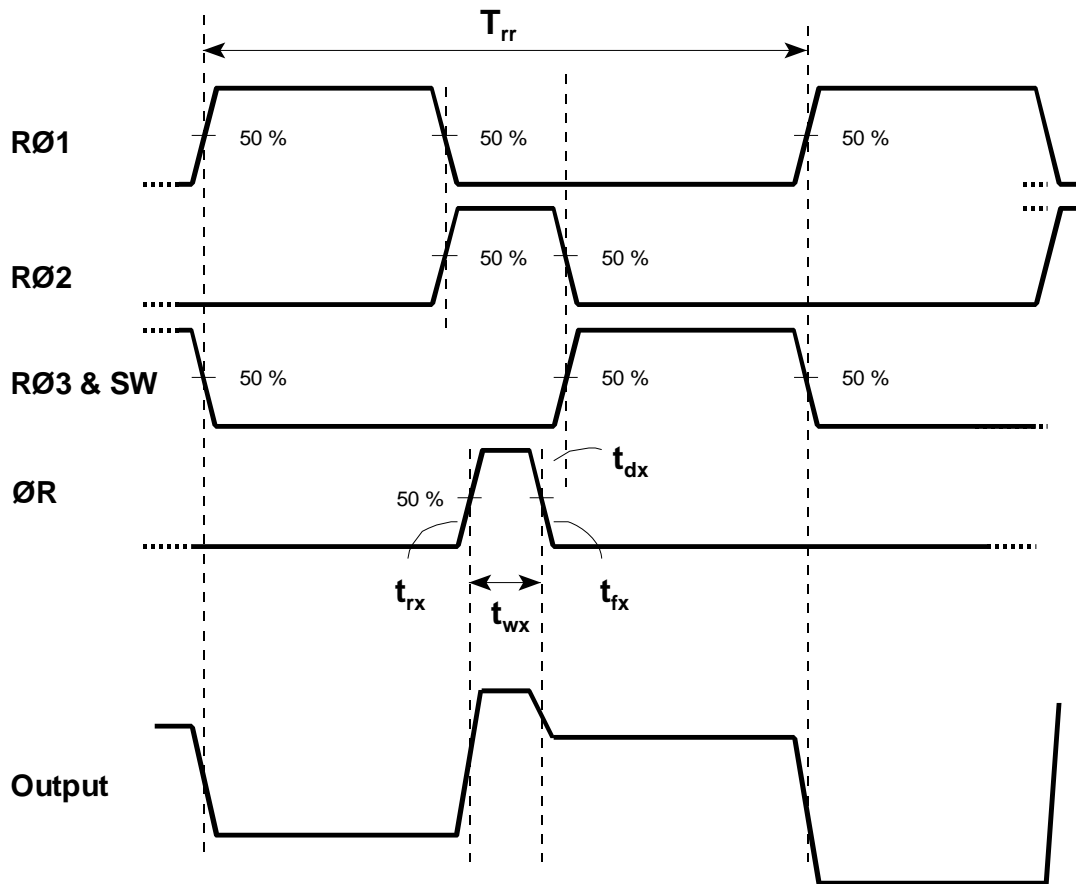

LINE OUTPUT FORMAT

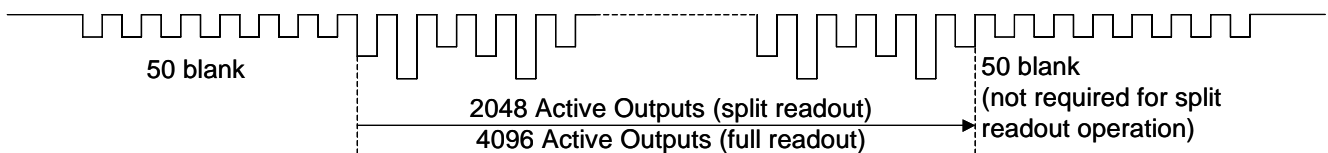

DETAIL OF VERTICAL LINE TRANSFER (Single line dump)

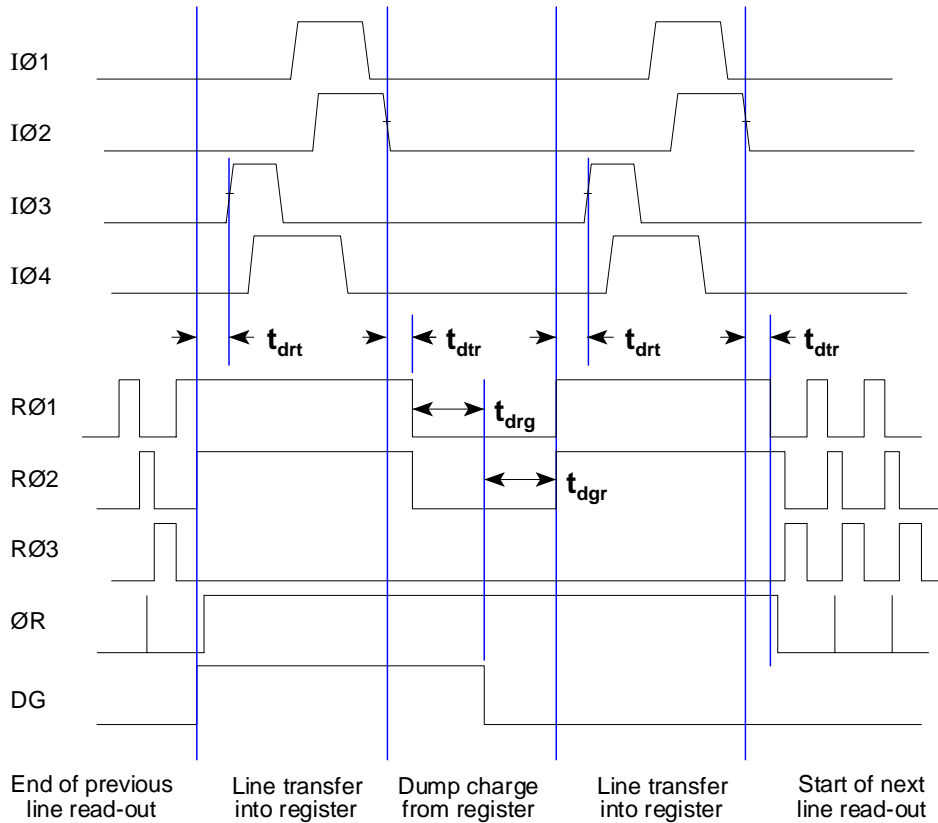

CLOCK TIMING REQUIREMENTS

Symbol	Description	Minimum	Typical	Maximum	Units
T_i	Line transfer time (see note 16)	110	135	(see note 18)	μs
t_{oi}	Image clock pulse edge overlap	12	15	(see note 18)	μs
t_{ri}	Image clock and transfer gate pulse rise time	1	2	$0.3 t_{oi}$	μs
t_{fi}	Image clock pulse fall time	1	2	$0.3 t_{oi}$	μs
t_{drt}	Delay time, RØ stop to IØ rising	5	6	(see note 18)	μs
t_{dtr}	Delay time, IØ falling to RØ start	5	15	(see note 18)	μs
T_{rr}	Register clock period (see note 19)	200 (TBC)	1000	(see note 18)	ns
t_{drg}	Delay time, RØ falling to DG rising	5	20	N/A	μs
t_{dgr}	Delay time, DG falling to RØ rising	5	20	N/A	μs
t_{rr}	Register clock pulse rise time	10	50	(see note 18)	ns
T_{fr}	Register clock pulse fall time	10	50	(see note 18)	ns
t_{or}	Register clock pulse edge overlap	10	50	(see note 18)	ns
t_{wx}	Reset pulse width (see note 19)	$>3 t_{rx}$	50	100	ns
t_{rx}	Reset pulse rise time	2	20	30	ns
t_{fx}	Reset pulse fall time	2	20	30	ns

NOTES

16. Generally $T_i = t_{drt} + 7t_{oi} + t_{dtr}$.

17. The RØ2 pulse-width is normally minimised, as shown, such that the RØ1 and RØ3 pulse widths can be increased to maximise the output reset (or reference) and signal sampling intervals.

18. As set by any system specifications.

19. The typical timing is for read-out at frequencies in the region of 1 MHz.

PACKAGE DETAIL

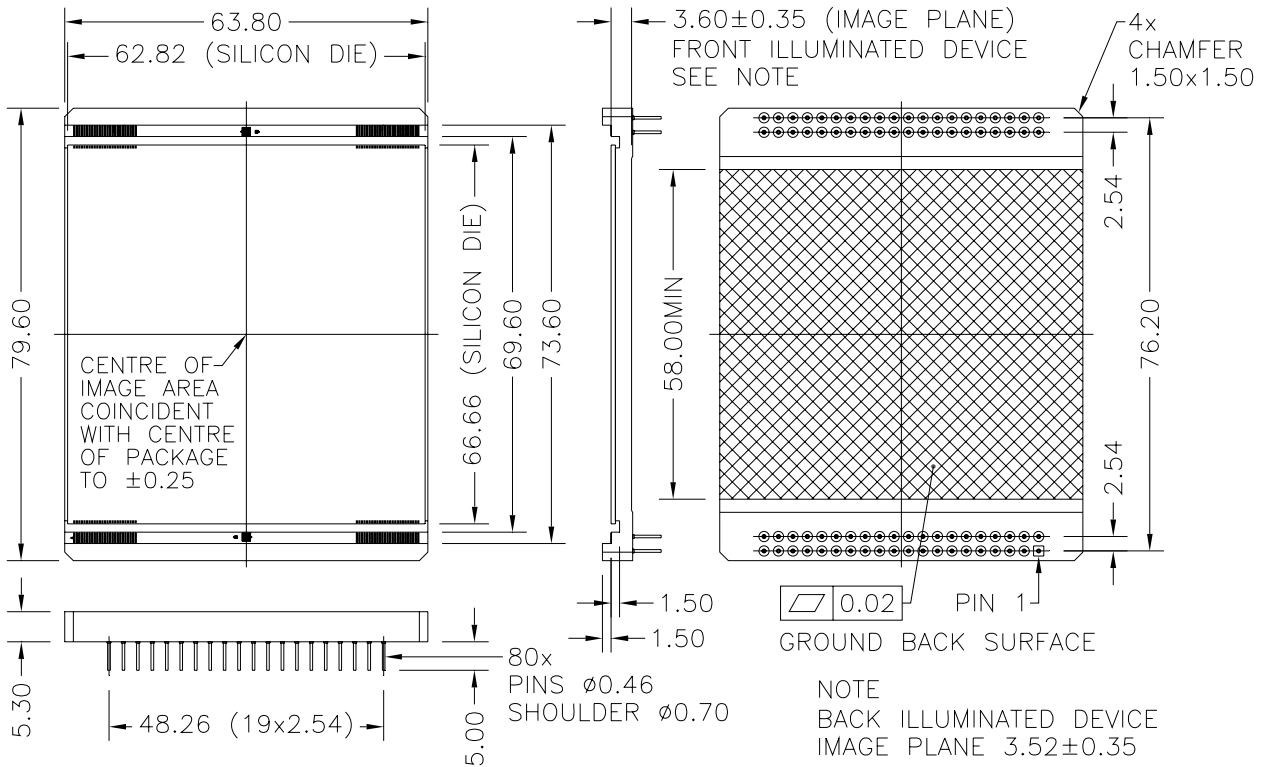

HANDLING CCD SENSORS

CCD sensors, in common with most high performance MOS IC devices, are static sensitive. In certain cases, a discharge of static electricity may destroy or irreversibly degrade the device. Accordingly, full antistatic handling precautions should be taken whenever using a CCD sensor or module. These include:

- Working at a fully grounded workbench
- Operator wearing a grounded wrist strap
- All receiving sockets to be positively grounded

Evidence of incorrect handling will invalidate the warranty. All devices are provided with internal protection circuits to the gate electrodes (i.e. all CCD pins except SS, DD, RD, OD and OS) but not to the other pins.

The devices are assembled in a clean room environment. e2v technologies recommend that similar precautions are taken to avoid contaminating the active surface.

HIGH ENERGY RADIATION

Performance parameters will begin to change if the device is subject to ionising radiation. Characterisation data is held at e2v technologies with whom it is recommended that contact be made if devices are to be operated in any high radiation environment.

TEMPERATURE RANGE

Operating temperature range 153 - 323 K

Storage temperature range 143 - 373 K

Full performance is only guaranteed at the nominal operating temperature of 248 K.

Operation or storage in humid conditions may give rise to ice on the surface when the sensor taken to low ambient temperatures, thereby causing irreversible damage.

Maximum rate of heating or cooling: 5 K/min.