

### INTRODUCTION

This device extends e2v's family of scientific CCD sensors. The CCD231 has been designed to provide a large image area for demanding astronomical and scientific imaging applications. Back-illuminated spectral response combined with very low readout noise give exceptional sensitivity.

### DESCRIPTION

The sensor has an image area having 4096 x 4096 pixels, split readout registers at both top and bottom with charge detection amplifiers at both ends. The pixel size is 15  $\mu\text{m}$  square. The image area has four separately connected sections to allow full-frame, frame transfer, split full frame or split frame-transfer modes. Depending on the mode, the readout can be through 1, 2 or 4 of the output circuits. A gate-controlled drain is also provided to allow fast dumping of unwanted data.

The output amplifier is designed to give very low noise at readout rates of up to 3 MHz. The low output impedance simplifies the interface with external electronics and the optional dummy outputs are provided to facilitate common mode rejection.

The package provides a compact footprint with guaranteed flatness at cryogenic temperatures. Connections are made at the top and bottom of the device via two flexi connectors that also provide a thermal break. The sides may be close butted if needed.

Specifications are tested and guaranteed at 173 K ( $-100^\circ\text{C}$ ).

The CCD231 devices described here are non-inverted (non-MPP) types.

### VARIANTS

Standard silicon and deep depletion silicon device types are available with a range of AR coatings. Graded coatings and two-layer coatings are available as custom variants.

Devices with other formats (e.g. 8192 x 3172 pixels) or 3-side butting can also be provided in the same family.

A version (CCD230) is also available with an alternative amplifier with higher charge handling capacity and higher speed (up to 5 MHz), but with slightly increased noise.

An alternate ceramic/PGA package is also available.

Consult e2v technologies for further information on any of the above options.

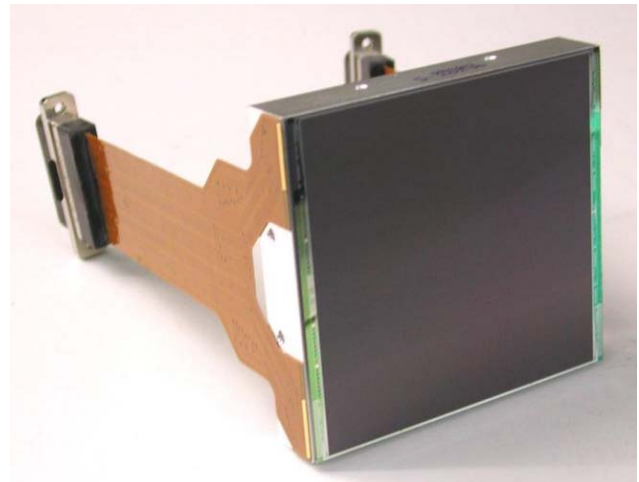

### SUMMARY PERFORMANCE (Typical)

Number of pixels	4096(H) x 4112(V)
Pixel size	15 $\mu\text{m}$ square
Image area	61.4 mm x 61.4 mm
Outputs	4
Package size	63.0 x 69.0 mm
Package format	silicon carbide with two flexi connectors
Focal plane height, above base	15.0 mm
Height tolerance	$\pm 10 \mu\text{m}$
Connectors	two 37-way micro-D
Flatness	$< 20 \mu\text{m}$ (peak to valley)
Amplifier sensitivity	7 $\mu\text{V}/\text{e}^-$
Readout noise	5 $\text{e}^-$ at 1 MHz 2 $\text{e}^-$ at 50 kHz
Maximum pixel data rate	3 MHz
Charge storage (pixel full well)	350,000 $\text{e}^-$
Dark signal	3 $\text{e}^-/\text{pixel}/\text{hour}$ (at $-100^\circ\text{C}$ )

Quoted performance parameters given here are "typical" values. Specification limits are shown later in this data sheet.

### Part References

CCD231-84-g-xxx                      g = cosmetic grade  
xxx = device-specific part number

CCD231-84-g-141..... standard silicon, astro-BB coated  
CCD231-84-g-142.... deep depletion silicon, astro-BB coated  
CCD231-84-g-E06 .deep depletion silicon, astro-ER1 coated  
CCD231-84-g-E56 ..... standard silicon, astro-mid coated  
CCD231-84-g-E57 .. deep depletion silicon, astro-mid coated

Whilst e2v technologies has taken care to ensure the accuracy of the information contained herein it accepts no responsibility for the consequences of any use thereof and also reserves the right to change the specification of goods without notice. e2v technologies accepts no liability beyond the set out in its standard conditions of sale in respect of infringement of third party patents arising from the use of tubes or other devices in accordance with information contained herein.

e2v technologies (uk) limited, Waterhouse Lane, Chelmsford, Essex CM1 2QU United Kingdom Telephone: +44 (0)1245 493493 Facsimile: +44 (0)1245 492492

e-mail: [enquiries@e2v.com](mailto:enquiries@e2v.com) Internet: [www.e2v.com](http://www.e2v.com) Holding Company: e2v technologies plc

e2v technologies inc. 520 White Plains Road, Suite 450, Tarrytown, NY10591 USA Telephone: (914) 592-6050 Facsimile: (914) 592-5148 e-mail: [enquiries@e2vtechnologies.us](mailto:enquiries@e2vtechnologies.us)

## PERFORMANCE (At 173 K unless stated)

### Electro-Optical Specification (CCD231 Normal Mode, see note 1)

	Min	Typical	Max	Units	Note
Peak charge storage (image)	275,000	350,000	-	e <sup>-</sup> /pixel	2(a)
Peak charge storage (register/SW): OG low (mode 1) OG high (mode 2)	- -	300,000 350,000	-	e <sup>-</sup> /pixel e <sup>-</sup> /pixel	2(b)
Output node capacity: OG low (mode 1) OG high (mode 2)	- -	200,000 600,000	- -	e <sup>-</sup> e <sup>-</sup>	2(c)
Output amplifier responsivity: mode 1 mode 2	5.0 -	7.0 2.5	- -	μV/e <sup>-</sup> μV/e <sup>-</sup>	3
Readout noise	-	2	3	e <sup>-</sup> rms	4
Maximum readout frequency	-	1000	3000	kHz	5
Dark signal: at 173 K at 153 K	- -	3 0.02	- 2.0	e <sup>-</sup> /pixel/hr e <sup>-</sup> /pixel/hr	6
Charge transfer efficiency: parallel serial	99.9990 99.9990	99.9995 99.9995	100 100	% %	7
Spectral range	300	-	1060	nm	
Peak quantum efficiency	-	90	-	%	

### NOTES

- Device performance will be within the limits specified by “max” and “min” when operated at the recommended voltages supplied with the test data and when measured at a register clock frequency of approximately 0.1 – 1.0 MHz. The noise as specified is separately measured in accordance with note 4.
- (a) Signal level at which resolution begins to degrade. Device is non-inverted (NIMO/non-MPP), for maximum full well.  
(b) The summing well capacity limits the charge in the register, and its value varies with mode as shown.  
(c) The signal handled by the output node (for linear operation) varies with mode as shown.
- Under normal operation (mode 1), SW is operated as a summing well or clocked as RØ3. OG is biased at a low DC level. Note: in this mode (with lowest read noise) the output cannot handle the full available pixel charge capacity.  
Alternatively (mode 2), SW may be operated as an output gate (and not therefore available for summing), biased at a low DC level, with OG raised to a high voltage (see note 9). This gives more charge-handling capacity (e.g. for higher level pixel binning). Charge transfer to the output now occurs as RØ2 goes low. In mode-2, the output noise will also increase by a factor of three.
- Measured with correlated double sampling at 50 kHz nominal (mode 1).
- Depending on the external load capacitance to be driven. The register will transfer charge at higher frequencies, but performance cannot be guaranteed.
- Dark signal is typically measured at a device temperature of 173 K. It is a strong function of temperature and the typical average (background) dark signal at any temperature T (Kelvin) between 150 K and 300 K is given by:  

$$Q_d/Q_{d0} = 122T^3e^{-6400/T}$$
 where Q<sub>d0</sub> is the dark current at 293 K.  
 Note that this is typical performance and some variation may be seen between devices. Dark current is lowest with the substrate voltage at +9 V, and somewhat higher with substrate at 0 V.
- Measured with a <sup>55</sup>Fe X-ray source. The CTE value is quoted for the complete clock cycle (i.e. not per phase).

# SPECTRAL RESPONSE

The table below gives guaranteed minimum values of the spectral response for several variants. PRNU is also shown.

	Standard silicon Astro Broadband	Standard silicon Astro Midband	Deep depletion silicon Astro Broadband	Deep depletion silicon Astro Midband	Deep depletion silicon Astro ER1 response	Maximum Pixel Response Non- Uniformity PRNU (1 $\sigma$ ) (%)
Wavelength (nm)	Minimum QE (%)	Minimum QE (%)	Minimum QE (%)	Minimum QE (%)	Minimum QE (%)	
350	40	20	40	20	20	-
400	70	50	70	50	35	3
500	80	80	75	80	65	-
650	75	80	70	80	80	3
900	25	25	40	40	45	5

See also the figures below. Devices with an alternate spectral response may be available. Consult e2v technologies.

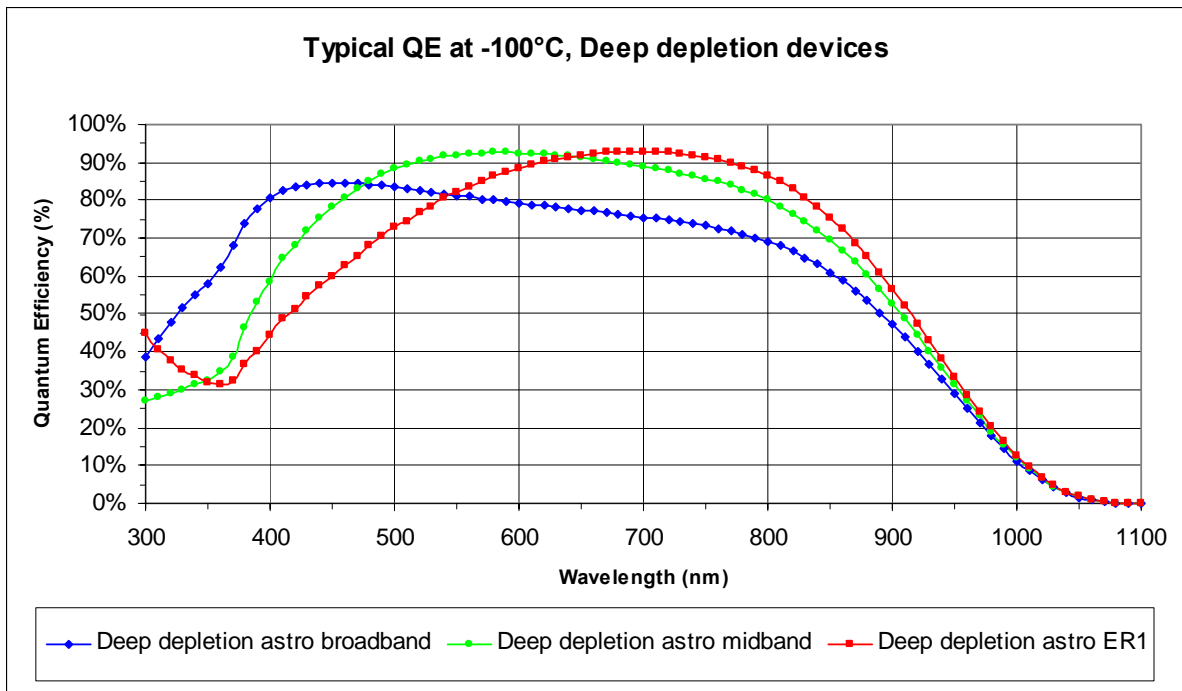
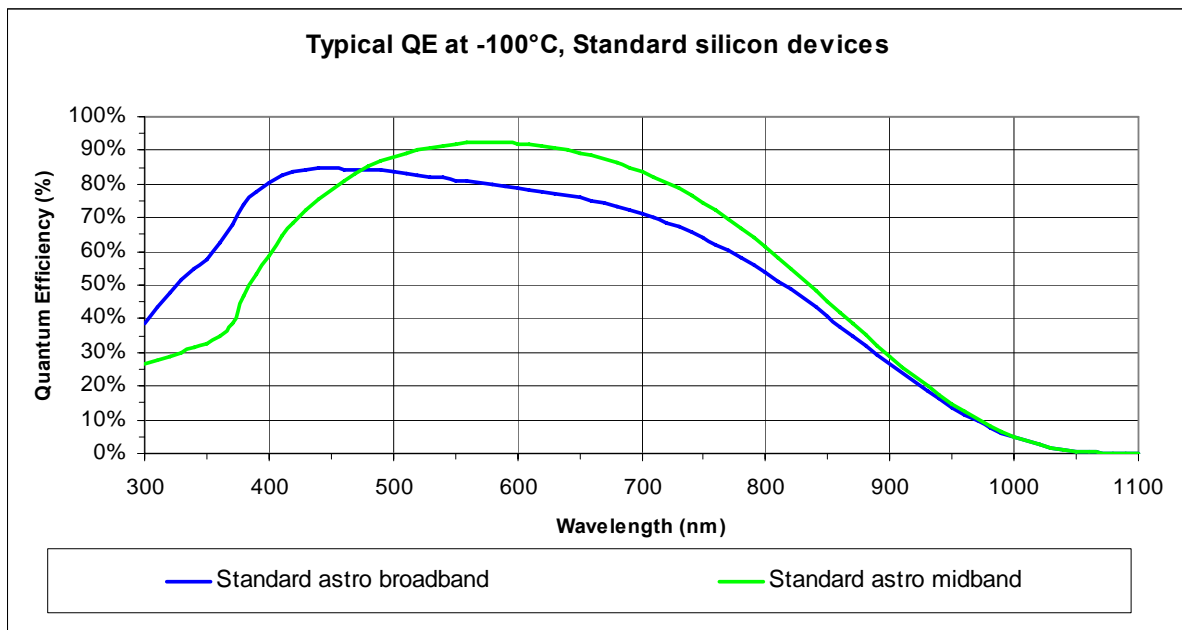

## COSMETIC SPECIFICATIONS

Maximum allowed defect levels are indicated below.

Grade	Guaranteed Specifications			Typical Values		
	0	1	2	0	1	2
Column defects - black or white	5	10	15	0	<3	<6
White spots	400	800	1200	<200	<400	<600
Total (black & white) spots	800	1500	2000	<400	<750	<1000
Traps > 200e-	10	15	20	<5	<10	<15

**Grades 0 and 1** are the defaults for science use.

**Grade 2** may have limited availability.

**Grade 5** devices are fully functional but with an image quality below that of grade 2, and may not meet all other specifications. Not all parameters may be tested.

## DEFINITIONS

<b>White spots</b>	A defect is counted as a white spot if the dark generation rate is $\geq 5 \text{ e}^-/\text{pixel/s}$ at 173 K. (which is also equivalent to $\geq 100 \text{ e}^-/\text{hour}$ at 153 K). The temperature dependence is the same as for the mean dark signal; see note 6 above.
<b>Black spots</b>	A black spot defect is a pixel with a photo-response less than 50% of the local mean.
<b>Column defects</b>	A column is counted as a defect if it contains at least 100 white or dark single pixel defects.
<b>Traps</b>	A trap causes charge to be temporarily held in a pixel and these are counted as defects if the quantity of trapped charge is greater than $200 \text{ e}^-$
<b>Defect exclusion zone</b>	Defect measurements are excluded from the outer two rows and columns of the sensor.

## AMPLIFIER READ NOISE

The variation of typical read noise with operating frequency is shown below. (Measured using correlated double sampling with a pre-sampling bandwidth equal to twice the pixel rate in mode 1, temperature range 150 – 230 K).

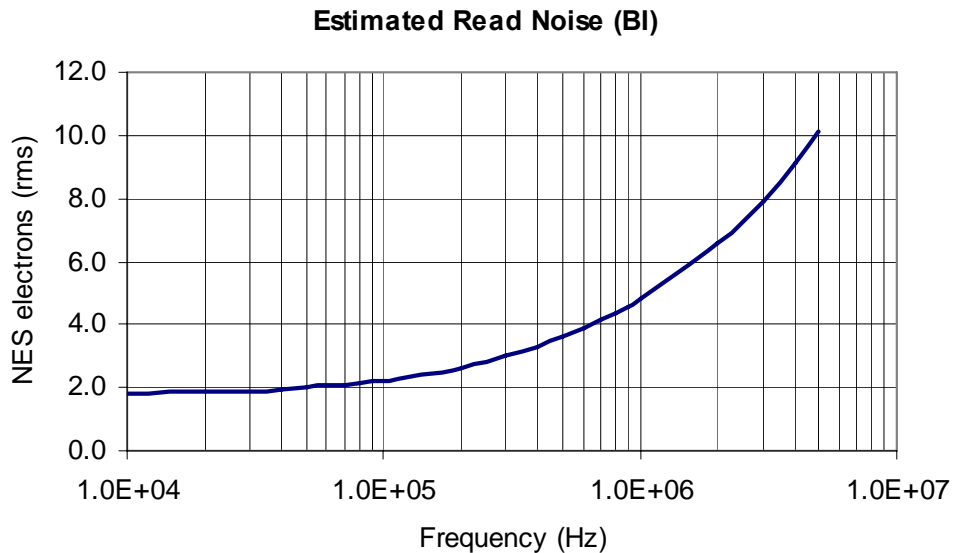

## DEFINITIONS

### Back-Thinning

A back-thinned CCD is fabricated on the front surface of the silicon and is subsequently processed for illumination from the reverse side. This avoids loss of transmission in the electrode layer (particularly significant at shorter wavelengths or with low energy X-rays). This process requires the silicon to be reduced to a thin layer by a combination of chemical and mechanical means. The surface is "passivated" and an anti-reflection coating may be added.

### AR Coating

Anti-reflection coatings are normally applied to the back illuminated CCD to further improve the quantum efficiency. Standard coatings optimise the response in the visible, ultra-violet or infrared regions. For X-ray detection an uncoated device may be preferable.

### Readout Noise

Readout noise is the random noise from the CCD output stage in the absence of signal. This noise introduces a random fluctuation in the output voltage that is superimposed on the detected signal.

The method of measurement involves reverse-clocking the register and determining the standard deviation of the output fluctuations, and then converting the result to an equivalent number of electrons using the known amplifier responsivity.

### Dummy Output

Each output has an associated "dummy" circuit on-chip, which is of identical design to the "real" circuit but receives no signal charge. The dummy output should have the same levels of clock feed-through, and can thus be used to suppress the similar component in the "real" signal output by means of a differential pre-amplifier. The penalty is that the noise is increased by a factor of  $\sqrt{2}$ . If not required the dummy outputs may be powered down.

### Dark Signal

This is the output signal of the device with zero illumination. This typically consists of thermally generated electrons within the semiconductor material, which are accumulated during signal integration. Dark signal is a strong function of temperature as described in note 6.

### Correlated Double Sampling

A technique for reducing the noise associated with the charge detection process by subtracting a first output sample taken just after reset from a second sample taken with charge present.

### Charge Transfer Efficiency

The fraction of charge stored in a CCD element that is transferred to the adjacent element by a single clock cycle. The charge not transferred remains in the original element, possibly in trapping states and may possibly be released into later elements. The value of CTE is not constant but varies with signal size, temperature and clock frequency.

# ARCHITECTURE

## Chip Schematic

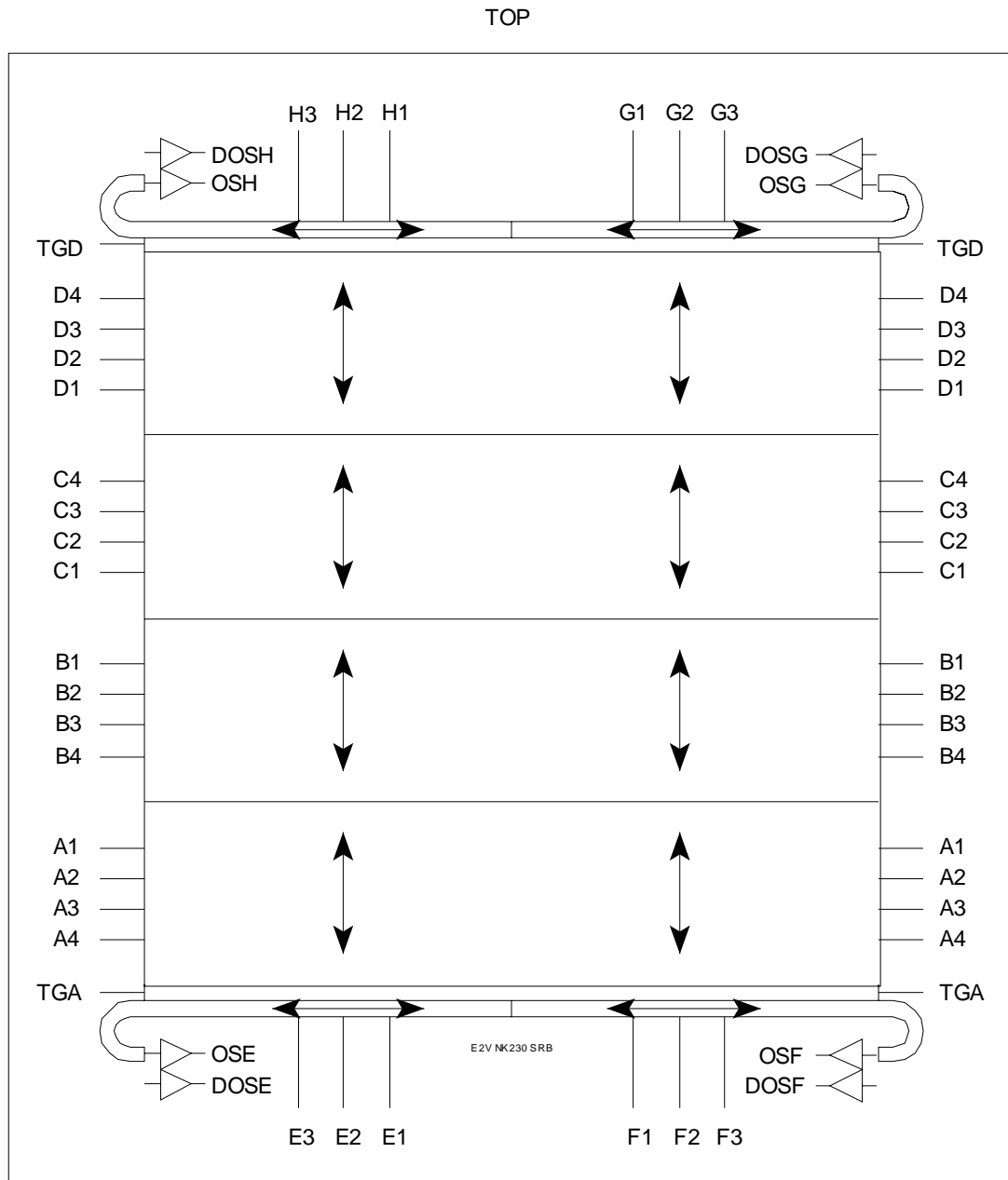

BOTTOM

Image sections A and D each have a total of 4096 (H) x 1032 (V) pixels.

Image sections B and C each have a total of 4096 (H) x 1024 (V) pixels.

Connector-1 (and flexi) is at the "bottom" of the device (register E/F); Connector-2 is at the "top" of the device (register G/H).

# ARRANGEMENT OF ELECTRODES

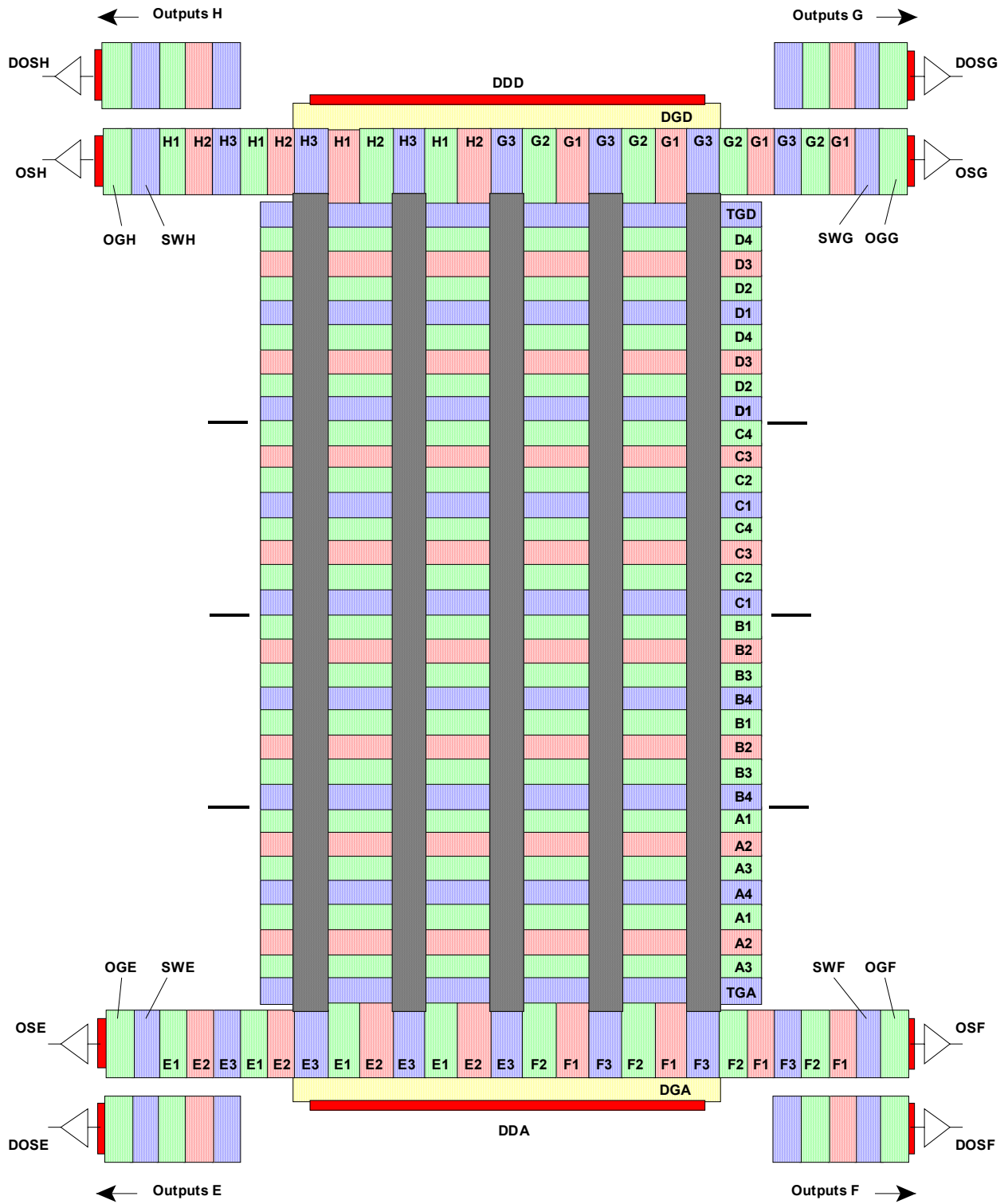

# OUTPUT CIRCUIT

X designates a specific output, namely E, F, G or H.

The 'mapping table' on p14 shows the relationship between serial drive phases (RØ1, etc.) and device clock pins (X1, X2 etc)

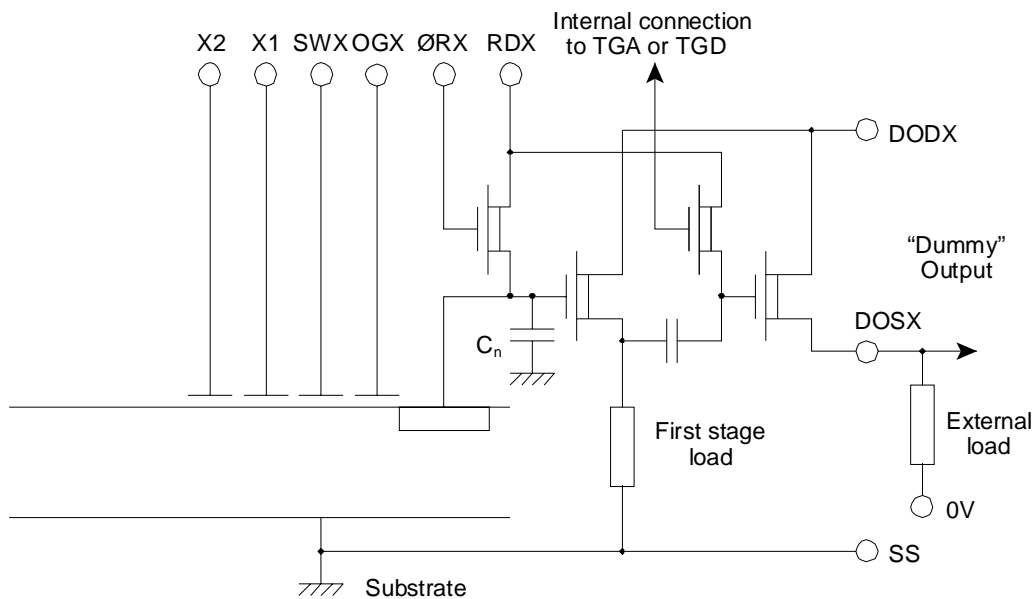
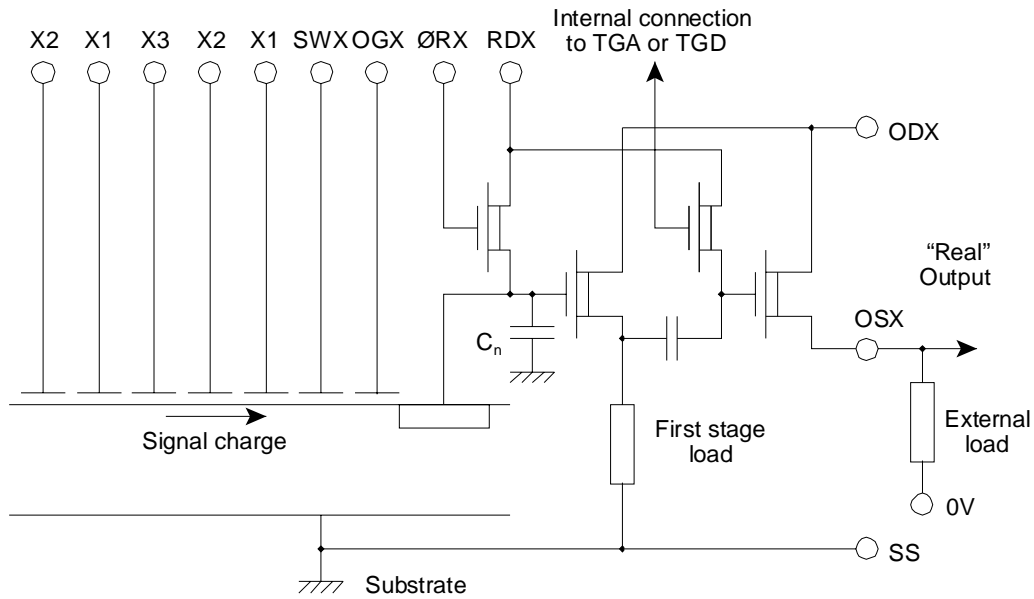

The first stage load of each output (real or dummy) draws a quiescent current of approximately 0.2 mA via SS.

The output circuit consists of two capacitor-coupled source-follower stages. The particular design has a very high responsivity to give lowest noise. The load for the first stage is on-chip and that for the second stage is external, as next described. The DC restoration circuitry requires a pulse at the start of line readout, and this is automatically obtained by an internal connection to the adjacent transfer gate, TG. Transferring a line of charges to the register thus automatically activates the circuitry. N.B. TG pulses still need to be applied at similar intervals if only the register and/or output circuit are being operated, e.g. for test or characterisation purposes.

If an output is to be powered down, it is recommended that either OD or DOD be set to SS voltage, taking care that the maximum ratings are never exceeded or that OD and DOD be disconnected. If external loads return to a voltage below SS they should also be disconnected.

# ELECTRICAL INTERFACE

## CONNECTIONS, TYPICAL VOLTAGES AND ABSOLUTE MAXIMUM RATINGS

Note that the hyphenated suffix symbols (e.g. ØR-E) indicate to which output any register or amplifier pin relates.

### CONNECTOR 1

PIN	REF	DESCRIPTION	CLOCK AMPLITUDE OR DC LEVEL (V) (see note 10)			MAX RATINGS with respect to V <sub>SS</sub> (V)
			Min	Typical	Max	
1	SS	Substrate (see note 12)	0	0	10	N/A
2	DOS-E	Dummy Output Source (E)	(see note 8)			N/A
3	OS-E	Output Source (E)	(see note 8)			N/A
4	OG-E	Output Gate (E) (see note 9)	1	2	(note 9)	±20
5	DG-A	Dump Gate (A) (see note 11)	-2	0	0.5	±20
6	ØR-E	Reset Gate (E) (see note 13)	9	12	14	±20
7	SWØ-E	Summing Well (E) (see note 9)	9	10	12	±20
8	E1	Register Clock Phase 1 (E)	9	10	12	±20
9	E2	Register Clock Phase 2 (E)	9	10	12	±20
10	E3 – F3	Register Clock Phase 3 (E and F)	9	10	12	±20
11	F1	Register Clock Phase 1 (F)	9	10	12	±20
12	F2	Register Clock Phase 2 (F)	9	10	12	±20
13	SWØ-F	Summing Well (F) (see note 9)	9	10	12	±20
14	ØR-F	Reset Gate (F) (see note 13)	9	12	14	±20
15	TG-A	Transfer Gate (A)	9	10	12	±20
16	OG-F	Output Gate (F) (see note 9)	1	2	(note 9)	±20
17	OS-F	Output Source (F)	(see note 8)			N/A
18	DOS-F	Dummy Output Source (F)	(see note 8)			N/A
19	SS	Substrate (see note 12)	0	0	10	N/A
20	DOD-E	Dummy Output Drain (E)	25	27.5	31	-0.3 to +35
21	RD-E	Reset Drain (E)	16	17	19	-0.3 to +25
22	OD-E	Output Drain (E)	25	27.5	31	-0.3 to +35
23	SS	Substrate (see note 12)	0	0	10	N/A
24	A4	Image Area Clock Phase 4 (A)	9	10	12	±20
25	A3	Image Area Clock Phase 3 (A)	9	10	12	±20
26	B4	Image Area Clock Phase 4 (B)	9	10	12	±20
27	B3	Image Area Clock Phase 3 (B)	9	10	12	±20
28	SS	Substrate (see note 12)	0	0	10	N/A
29	DD-A	Dump Drain (A)	25	29	31	-0.3 to +35
30	B1	Image Area Clock Phase 1 (B)	9	10	12	±20
31	B2	Image Area Clock Phase 2 (B)	9	10	12	±20
32	A1	Image Area Clock Phase 1 (A)	9	10	12	±20
33	A2	Image Area Clock Phase 2 (A)	9	10	12	±20
34	SS	Substrate (see note 12)	0	0	10	N/A
35	OD-F	Output Drain (F)	25	27.5	31	-0.3 to +35
36	RD-F	Reset Drain (F)	16	17	19	-0.3 to +25
37	DOD-F	Dummy Output Drain (F)	25	27.5	31	-0.3 to +35

## CONNECTOR 2

PIN	REF	DESCRIPTION	CLOCK AMPLITUDE OR DC LEVEL (V) (see note 10)			MAX RATINGS with respect to V <sub>SS</sub> (V)
			Min	Typical	Max	
1	SS	Substrate (see note 12)	0	0	10	N/A
2	DOS-G	Dummy Output Source (G)	(see note 8)			N/A
3	OS-G	Output Source (G)	(see note 8)			N/A
4	OG-G	Output Gate (G) (see note 9)	1	2	(note 9)	±20
5	DG-D	Dump Gate (D) (see note 11)	-2	0	0.5	±20
6	∅R-G	Reset Gate (G) (see note 13)	9	12	14	±20
7	SW∅-G	Summing Well (G) (see note 9)	9	10	12	±20
8	G1	Register Clock Phase 1 (G)	9	10	12	±20
9	G2	Register Clock Phase 2 (G)	9	10	12	±20
10	G3 – H3	Register Clock Phase 3 (G and H)	9	10	12	±20
11	H1	Register Clock Phase 1 (H)	9	10	12	±20
12	H2	Register Clock Phase 2 (H)	9	10	12	±20
13	SW∅-H	Summing Well (H) (see note 9)	9	10	12	±20
14	∅R-H	Reset Gate (H) (see note 13)	9	12	14	±20
15	TG-D	Transfer Gate (D)	9	10	12	±20
16	OG-H	Output Gate (H) (see note 9)	1	2	(note 9)	±20
17	OS-H	Output Source (H)	(see note 8)			N/A
18	DOS-H	Dummy Output Source (H)	(see note 8)			N/A
19	SS	Substrate (see note 12)	0	0	10	N/A
20	DOD-G	Dummy Output Drain (G)	25	27.5	31	-0.3 to +35
21	RD-G	Reset Drain (G)	16	17	19	-0.3 to +25
22	OD-G	Output Drain (G)	25	27.5	31	-0.3 to +35
23	SS	Substrate (see note 12)	0	0	10	N/A
24	D1	Image Area Clock Phase 1 (D)	9	10	12	±20
25	D2	Image Area Clock Phase 2 (D)	9	10	12	±20
26	C1	Image Area Clock Phase 1 (C)	9	10	12	±20
27	C2	Image Area Clock Phase 2 (C)	9	10	12	±20
28	SS	Substrate (see note 12)	0	0	10	N/A
29	DD-D	Dump Drain (D)	25	29	31	-0.3 to +35
30	C4	Image Area Clock Phase 4 (C)	9	10	12	±20
31	C3	Image Area Clock Phase 3 (C)	9	10	12	±20
32	D4	Image Area Clock Phase 4 (D)	9	10	12	±20
33	D3	Image Area Clock Phase 3 (D)	9	10	12	±20
34	SS	Substrate (see note 12)	0	0	10	N/A
35	OD-H	Output Drain (H)	25	27.5	31	-0.3 to +35
36	RD-H	Reset Drain (H)	16	17	19	-0.3 to +25
37	DOD-H	Dummy Output Drain (H)	25	27.5	31	-0.3 to +35

Note that parallel clock phase designations (sequence of phases) differ for connector-2 compared with connector-1.

### NOTES

8. Do not connect to voltage supply but use a ~5 mA current source or a ~5 kΩ external load. The quiescent voltage on OS is then about 6 - 8 V above the reset drain voltage and is typically 24 V. The current through these pins must not exceed 20 mA. Permanent damage may result if, in operation, OS or DOS experience short circuit conditions.

For highest speed operation the output load resistor can be reduced from 5 kΩ to approximately 2.2 kΩ, but note that this will increase power consumption. If the device is to be operated with a register clock period of below about 1 MHz then the load may be increased to 10 kΩ to reduce power consumption.

9. Default operation (mode 1) shown with OG set to OG-Lo, with a +2 V nominal value. In this mode SW may be clocked as R∅3 if a summing well function is not required. OG-Lo should have a maximum value of +5 V.

For alternative operation in a low responsivity mode (mode 2) with increased charge handling, OG should be set to OG-Hi and SW should be operated as OG-Lo (i.e. 2V typical). See below for appropriate OG-Hi values. Charge is now read out as RØ2 goes low.

See note 12 also for discussion about Substrate voltage (Vss). With high substrate voltage OG-Hi may be set to a nominal +20 V, which offers best linearity in mode-2. With low substrate voltage, the allowed maximum value of OG-Hi is limited to a nominal +18 V; the lower OG-Hi value has a greater non-linearity.

- 10. To ensure that any device can be operated the camera should be designed so that any value in the range “min” to “max” can be provided. All operating voltages are with respect to image clock low (nominally 0 V).

The clock pulse low levels should be in the range  $0 \pm 0.5$  V for image clocks. The register and SW clock low level should be +1 V higher. Reset clock low may be nominally 0 V or +1 V.

In all cases, specific recommended settings will be supplied with each science-grade sensor.

- 11. Non-charge dumping level shown. For charge dumping, DG should be pulsed to  $12 \pm 2$  V.
- 12. The substrate voltage (Vss) has a default recommended value of 0 V (“low” substrate). This is particularly recommended for deep-depletion device variants, since it optimises depletion depth for best Point Spread Function. Devices may alternatively be operated at “high” substrate, with  $V_{ss} = 9$  V. The high substrate setting offers slightly lower dark current, although this is usually not of primary concern when the device is cryogenically cooled.

The substrate setting has some consequence for the allowed OG upper voltage level, as discussed in note 9.

- 13. Standard silicon variants are expected to be used with ØR at +10 V or more; deep depletion variants require at least +12 V. A higher value will give a correspondingly higher reset feedthrough signal in the device output (OS).

### PIN CONNECTIONS (View facing pins of connector)

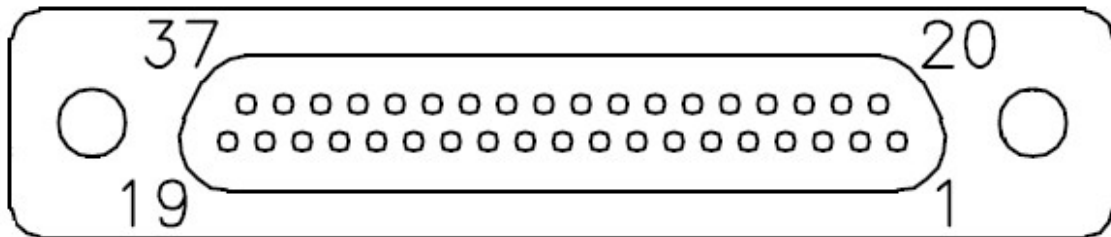

This numbering applies to all connectors. The connector is a Glenair 37P micro D type.

## ELECTRICAL INTERFACE CHARACTERISTICS

### Electrode capacitances (defined at mid-clock level)

	Typical	Units
I $\emptyset$ /I $\emptyset$ inter-phase [A, B, C and D]	10	nF
I $\emptyset$ /SS [A, B, C and D]	5	nF
Transfer gates [TGA, TGD]	75	pF
R $\emptyset$ total [E1, F1, G1, H1]	190	pF
R $\emptyset$ total [E2, F2, G2, H2]	175	pF
R $\emptyset$ total [E3, F3, G3, H3]	155	pF

The total capacitance on each phase is the sum of the inter-phase capacitance to each of the adjacent phases and the capacitance of the phase to substrate. For example, the total capacitance on phase A1 is 2 times 10 nF plus 5 nF for a total of 25 nF.

The amplifier output impedance is typically 400  $\Omega$ .

### POWER UP/POWER DOWN

When powering the device up or down it is critical that any specified maximum rating is not exceeded. Specifically the voltage for the amplifier and dump drains (pins 20, 21, 22, 29, 35, 36 and 37) must never be taken negative with respect to the substrate. Hence, if the substrate is to be operated at a positive voltage (e.g. to minimise dark current) then the drive electronics should have a switch-on sequence which powers up all the drains to their positive voltages before the substrate voltage starts to increase from zero.

It is also important to ensure that excess currents (see note 8) do not flow in the OS or DOS pins. Such currents could arise from rapid charging of a signal coupling capacitor or from an incorrectly biased DC-coupled preamplifier.

Similarly, for powering down, the substrate must be taken to zero voltage before the drains.

### POWER CONSUMPTION

The power dissipated within the CCD is a combination of the static dissipation of the amplifiers and the dynamic dissipation from the parallel and serial clocking (i.e. driving the capacitive loads).

The table below gives representative values for the components of the on-chip power dissipation for the case of continuous split-frame line-by-line readout using both registers and all the output circuits with both real and dummy amplifiers activated. The frequency is that for clocking the serial register and an appropriate value of the amplifier load is utilised in each case.

Readout frequency	Line time	Amplifier load	Power dissipation			
			Amplifiers	Serial clocks	Parallel clocks	Total
100 kHz	21 ms	10 k $\Omega$	165 mW	17 mW	3 mW	185 mW
1 MHz	2.2 ms	5 k $\Omega$	275 mW	170 mW	30 mW	475 mW
3 MHz	800 $\mu$ s	2.2 k $\Omega$	525 mW	510 mW	90 mW	1,125 mW

The dissipation reduces to only that of the amplifiers during the time that charge is being collected in the image sections with both the parallel and serial clocks static.

# FRAME READOUT MODES

The device can be operated in a full-frame or split full-frame mode with readout from one, two or four amplifiers. These modes are determined by the clock pulse sequences applied to the image and register clocks. The diagrams below show some of the transfer options that are possible.

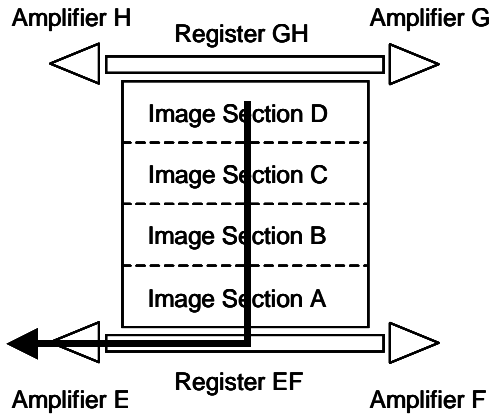

*Full frame read-out through one amplifier*

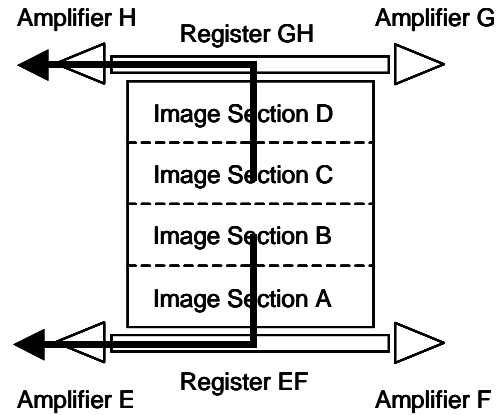

*Split full frame read-out through two amplifiers*

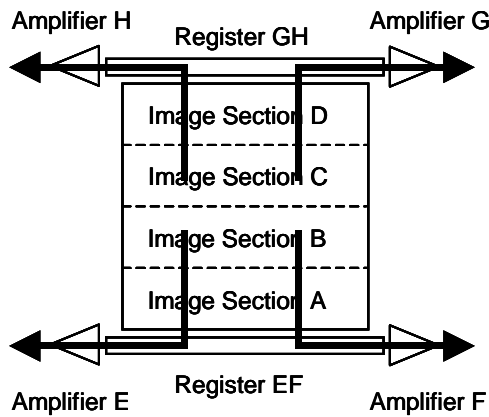

*Split full frame read-out through four amplifiers*

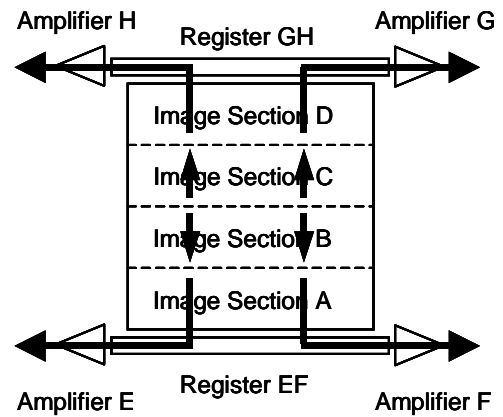

*Split frame transfer through four amplifiers*

If the applied drive pulses are designated IØ1, IØ2, IØ3 and IØ4, then connections should be made as tabulated below to effect the following directions of transfer.

	IØ1	IØ2	IØ3	IØ4	
A section transfer towards E-F register	A1	A2	A3	A4	TGA = IØ4
B section transfer towards E-F register	B1	B2	B3	B4	
C section transfer towards G-H register	C1	C2	C3	C4	
D section transfer towards G-H register	D1	D2	D3	D4	TGD = IØ1
A section transfer towards G-H register	A4	A3	A2	A1	TGA = "low"
B section transfer towards G-H register	B4	B3	B2	B1	
C section transfer towards E-F register	C4	C3	C2	C1	
D section transfer towards E-F register	D4	D3	D2	D1	TGD = "low"

The first four transfer sequences are for split frame readout. The second four are for reversing the transfer direction in either section for readout to only one of the registers. For example, using sequences 1, 2, 7 and 8 reads the whole device out through register E-F.

Transfer from the image section to the register is into the phase 1 and 2 electrodes, i.e. E1, F1, G1, H1, E2, F2, G2 and H2. These electrodes must be held at clock "high" level during the process. If the register pulses are designated RØ1, RØ2 and RØ3, then connections should be made as tabulated below to effect the following directions of transfer.

Clock Generator Drive Pulse Name	RØ1	RØ2	RØ3
E section transfer towards E output	E2	E1	E3
F section transfer towards F output	F2	F1	F3
G section transfer towards G output	G2	G1	G3
H section transfer towards H output	H2	H1	H3
E section transfer towards F output	E1	E2	E3
F section transfer towards E output	F1	F2	F3
G section transfer towards H output	G1	G2	G3
H section transfer towards G output	H1	H2	H3

The first four sequences are for split register readout to all four outputs. The second four are for the reversal of direction in any half-section.

The last electrode before the output gate is separately connected to give the function of a summing well (SW). In normal readout (i.e. if not used for summing), SW is clocked as RØ3. For summing, the selected SW gate is held at clock "high" level for the required number of readout cycles, and then clocked as RØ3 to output charge.

Alternatively, SW may be operated as a second output gate to provide the option of operation in low gain/high signal mode (mode 2) with OG high. If this mode of operation is used, then the sequencing of the output clocks must be changed, as charge now transfers into the output node as RØ2 goes low (see notes 3 and 9).

Image phases 2 and 3 should be held high during signal collection, as shown in the following figures.

# FRAME READOUT TIMING DIAGRAM

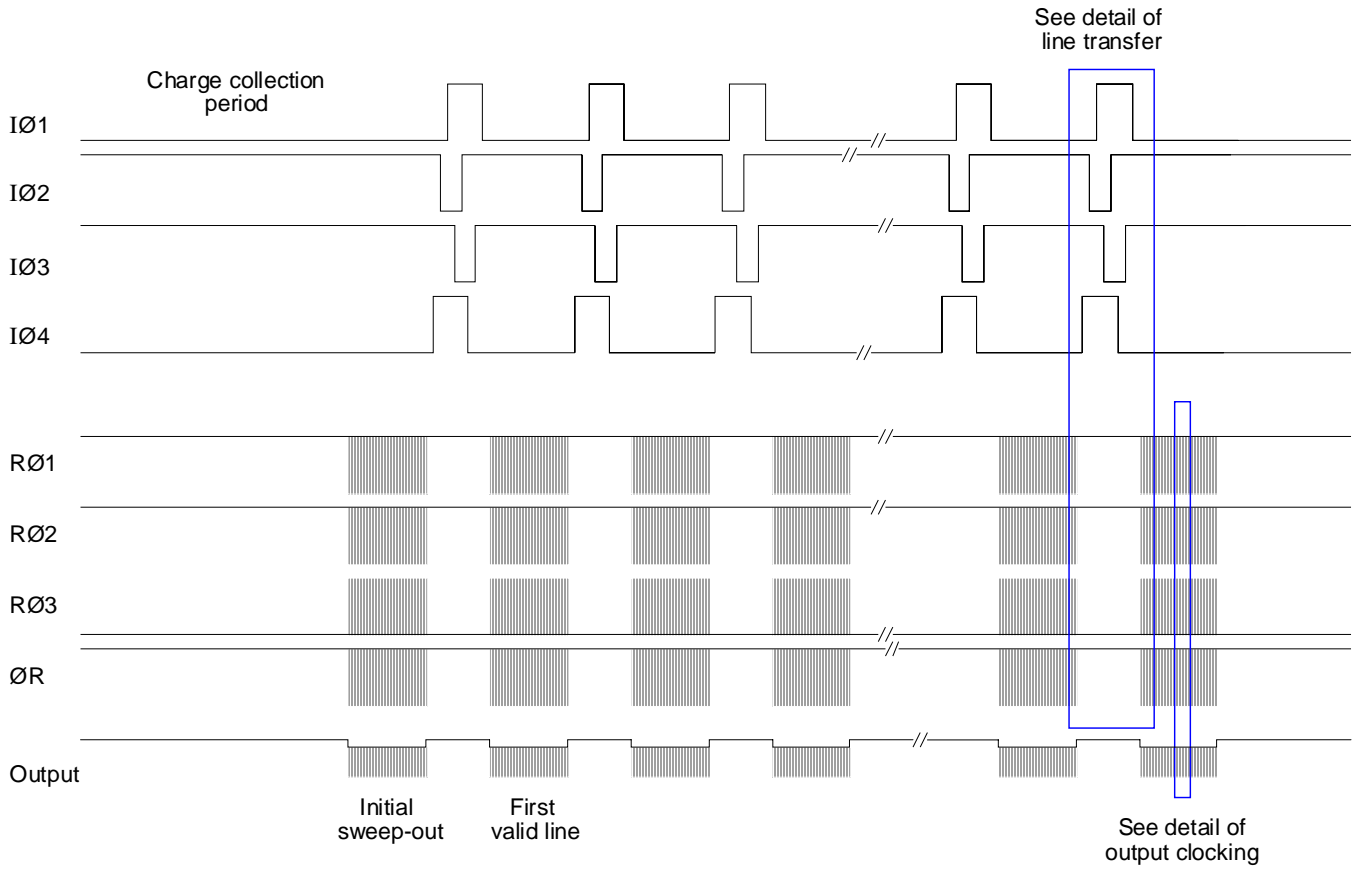

# DETAIL OF LINE TRANSFER

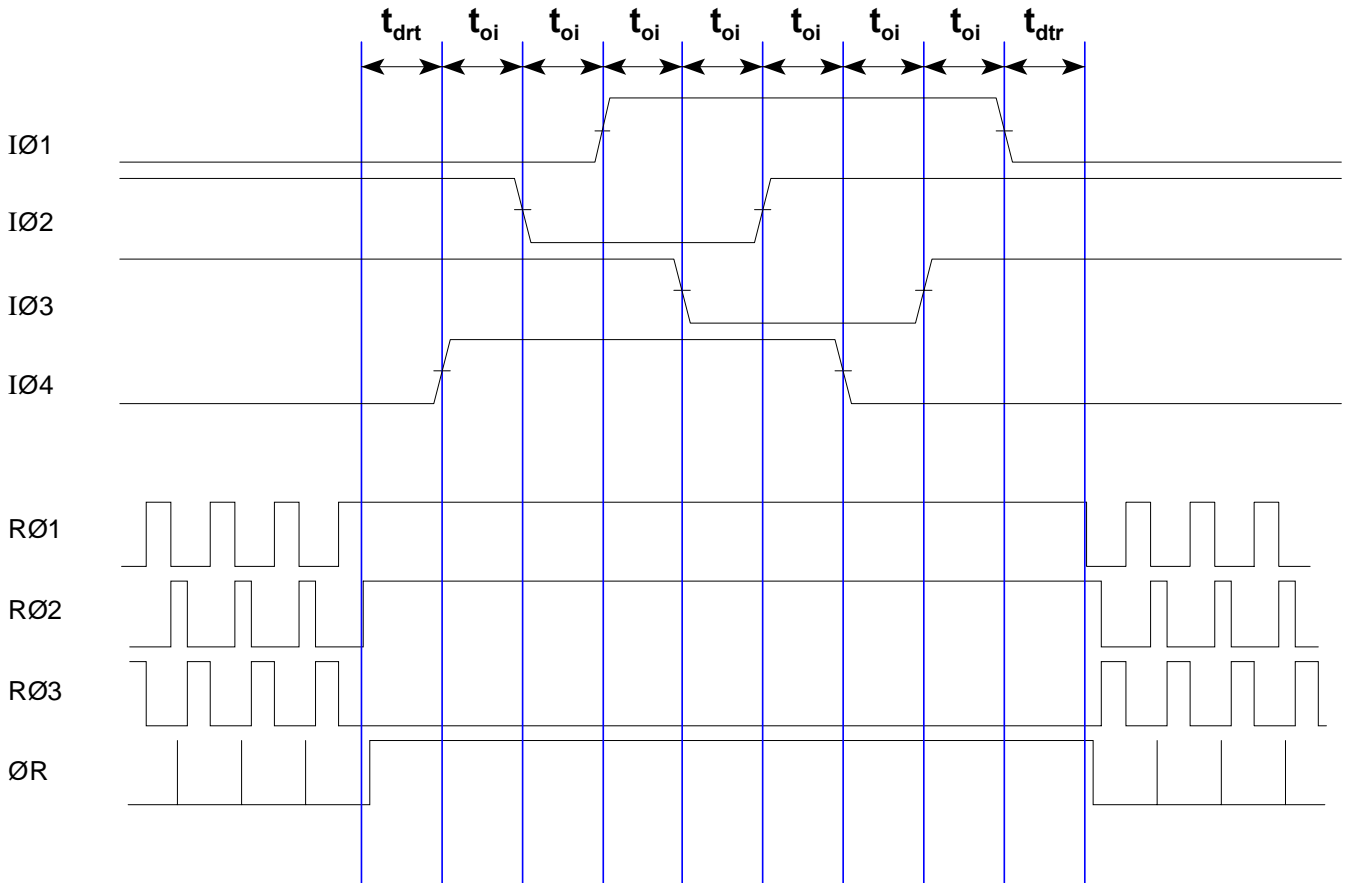

## DETAIL OF OUTPUT CLOCKING (with SW clocked as RØ3)

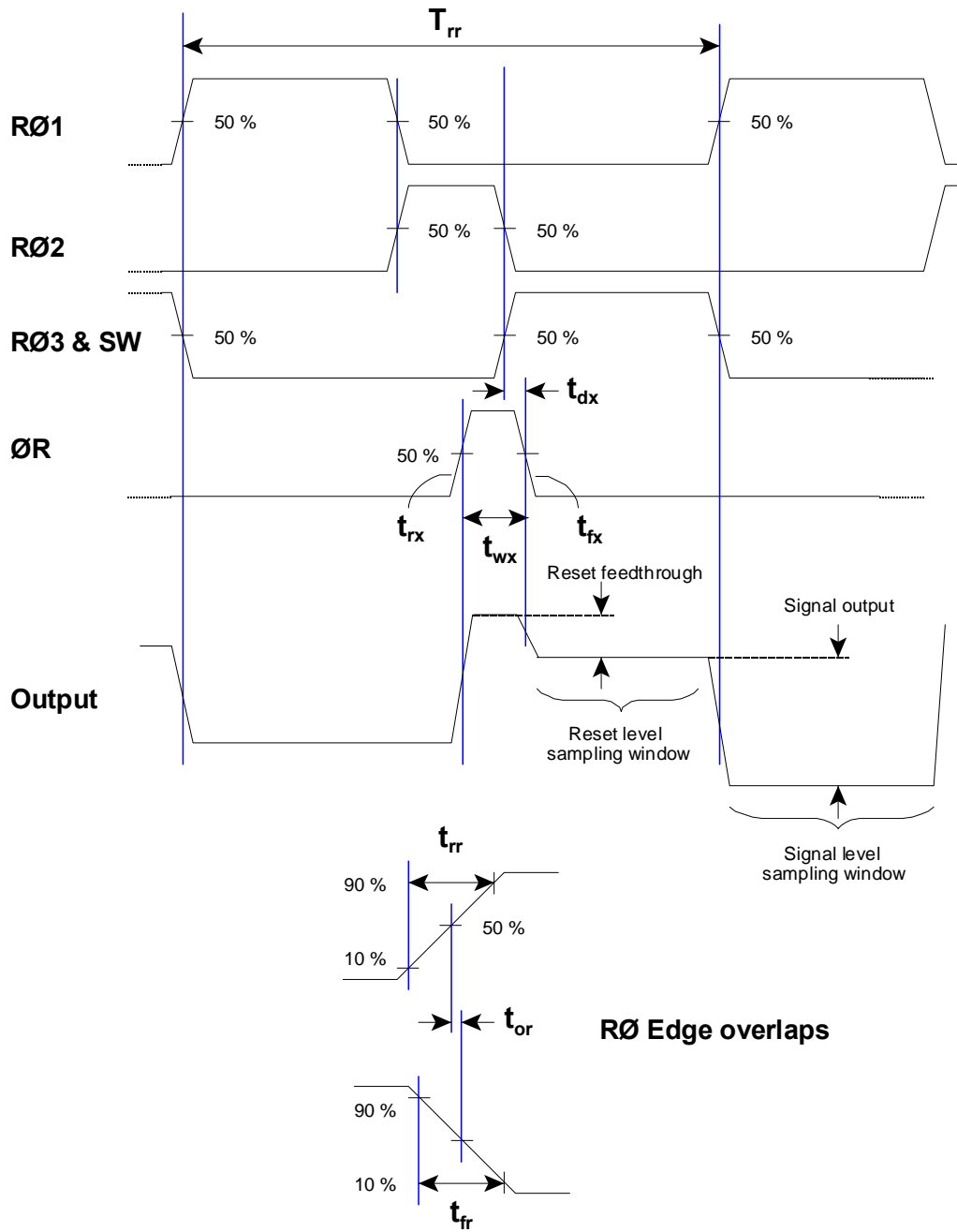

## LINE OUTPUT FORMAT

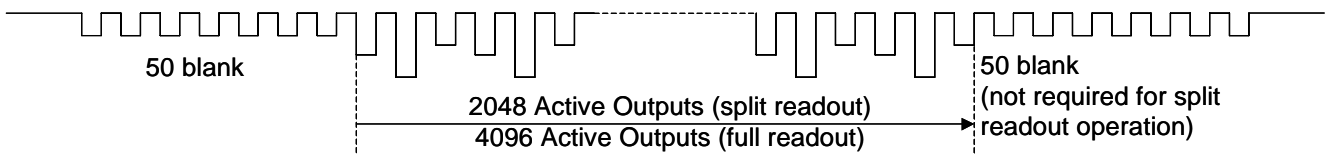

## DETAIL OF VERTICAL LINE TRANSFER (Single line dump)

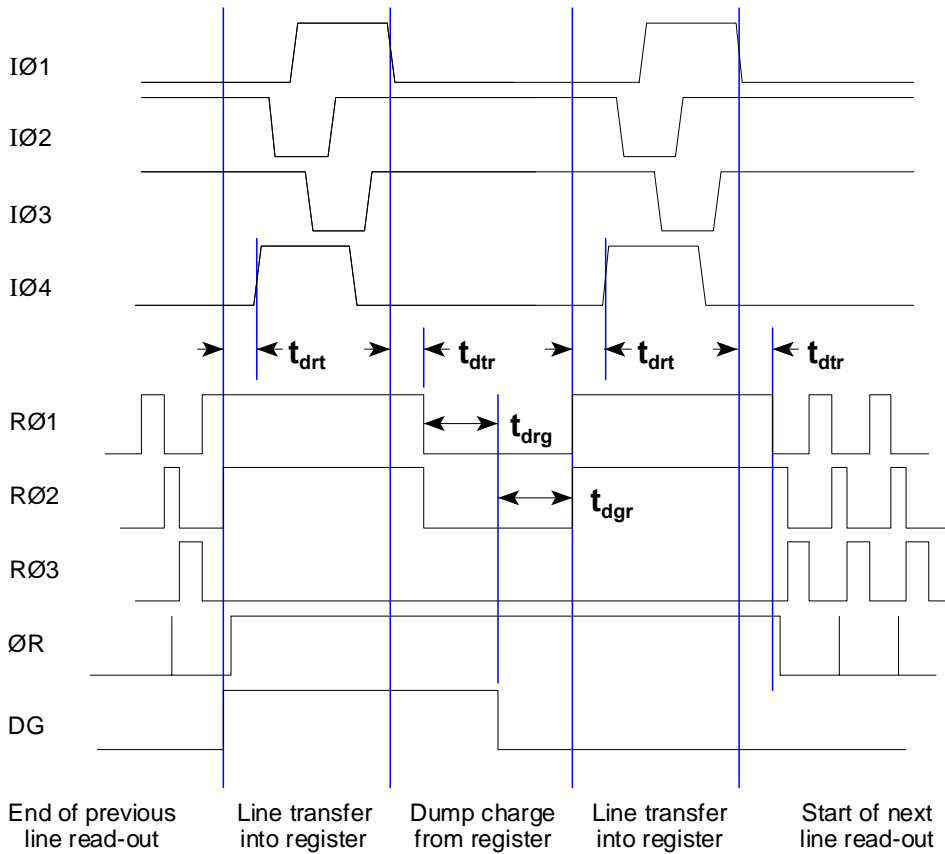

## CLOCK TIMING REQUIREMENTS

Symbol	Description	Minimum	Typical	Maximum	Units
$T_i$	Line transfer time (see note 14)	65	75	(see note 16)	$\mu\text{s}$
$t_{oi}$	Image clock pulse edge overlap	7.5	10	(see note 16)	$\mu\text{s}$
$t_{ri}$	Image clock and transfer gate pulse rise time	1	1	$0.3 t_{oi}$	$\mu\text{s}$
$t_{fi}$	Image clock pulse fall time	1	1	$0.3 t_{oi}$	$\mu\text{s}$
$t_{drt}$	Delay time, RØ stop to IØ rising	5	10	(see note 16)	$\mu\text{s}$
$t_{dtr}$	Delay time, IØ falling to RØ start	7.5	10	(see note 16)	$\mu\text{s}$
$t_{drg}$	Delay time, RØ falling to DG rising	10	10	N/A	$\mu\text{s}$
$t_{dgr}$	Delay time, DG falling to RØ rising	7.5	10	N/A	$\mu\text{s}$
$T_{rr}$	Register clock period (see notes 17 and 18)	300 (TBC)	2000	(see note 16)	ns
$t_{rr}$	Register clock pulse rise time	10	50	$0.05T_{rr}$	ns
$t_{fr}$	Register clock pulse fall time	10	50	$0.05T_{rr}$	ns
$t_{or}$	Register clock pulse edge overlap	0	50	$0.05T_{rr}$	ns
$t_{wx}$	Reset pulse width (see note 15)	$>3 t_{rx}$	300	$0.2T_{rr}$	ns
$t_{rx}$	Reset pulse rise time	10	40	50	ns
$t_{fx}$	Reset pulse fall time	10	40	50	ns
$t_{dx}$	Delay time, RØ falling to ØR falling	10	100	$0.05T_{rr}$	ns

## NOTES

14. Generally  $T_i = t_{drt} + 7t_{oi} + t_{dtr}$ .

15. The RØ2 pulse-width is normally minimised, as shown, such that the RØ1 and RØ3 pulse widths can be increased to maximise the output reset and signal sampling intervals.

16. As set by any system specifications.

17. The typical timing is for readout at frequencies in the region of 500 kHz.

18. For highest speed operation the output load resistor can be reduced from 5 k $\Omega$  to approximately 2.2 k $\Omega$ , but note that this will increase power consumption. If the device is to be operated with a register clock period of below about 1 MHz, then the load may be increased to 10 k $\Omega$  to reduce power consumption.

# PACKAGE DETAIL

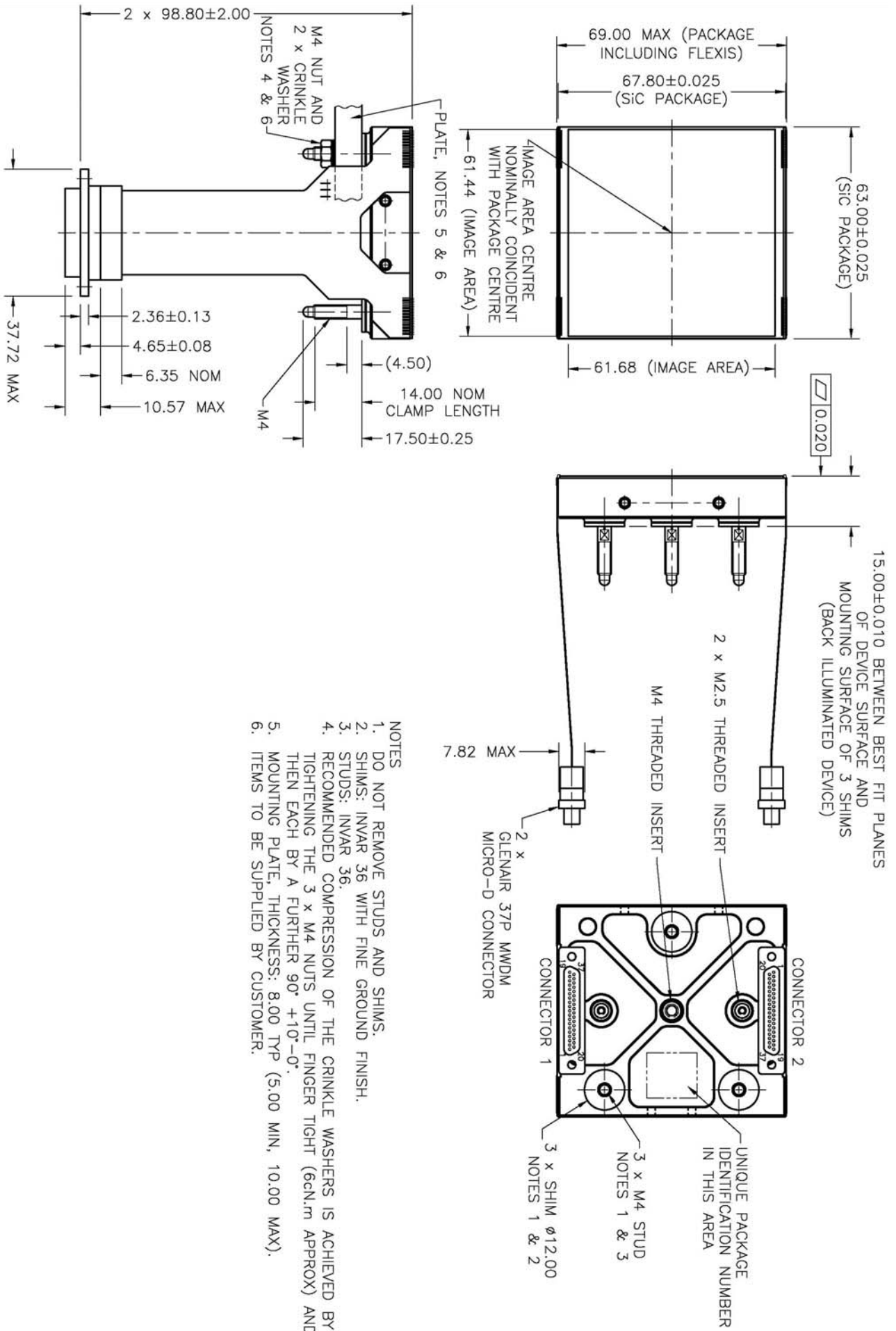

- NOTES
- DO NOT REMOVE STUDS AND SHIMS.
  - SHIMS: INVAR 36 WITH FINE GROUND FINISH.
  - STUDS: INVAR 36.
  - RECOMMENDED COMPRESSION OF THE CRINKLE WASHERS IS ACHIEVED BY TIGHTENING THE 3 x M4 NUTS UNTIL FINGER TIGHT (6cN.m APPROX) AND THEN EACH BY A FURTHER 90° +10°-0°.
  - MOUNTING PLATE, THICKNESS: 8.00 TYP (5.00 MIN, 10.00 MAX).
  - ITEMS TO BE SUPPLIED BY CUSTOMER.

## HANDLING CCD SENSORS

CCD sensors, in common with most high performance MOS IC devices, are static sensitive. In certain cases, a discharge of static electricity may destroy or irreversibly degrade the device. Accordingly, full antistatic handling precautions should be taken whenever using a CCD sensor or module. These include:

- Working at a fully grounded workbench
- Operator wearing a grounded wrist strap
- All receiving sockets to be positively grounded

Evidence of incorrect handling will invalidate the warranty. All devices are provided with internal protection circuits to the gate electrodes (i.e. all CCD pins except SS, DD, RD, OD and OS) but not to the other pins.

The devices are assembled in a clean room environment. e2v technologies recommend that similar precautions are taken to avoid contaminating the active surface.

## HIGH ENERGY RADIATION

Performance parameters will begin to change if the device is subject to ionising radiation. Characterisation data is held at e2v technologies with whom it is recommended that contact be made if devices are to be operated in any high radiation environment.

## TEMPERATURE RANGE

Operating temperature range 153 - 323 K

Storage temperature range 143 - 373 K

Performance parameters are measured with the device at a temperature of 173 K and, as a result, full performance is only guaranteed at this nominal operating temperature.

Operation or storage in humid conditions may give rise to ice on the surface when the sensor taken to low ambient temperatures, thereby causing irreversible damage.

Maximum rate of heating or cooling: 5 K/min.